



AVANTHI INSTITUTE OF ENGINEERING AND TECHNOLOGY

(Approved by AICTE, Regg. By Govt. of T.S & Affiliated to JNTUH, Hyderabad)

NAAC "B++" Accredited Institute

Gunthapally (V), Abdullapurmet(M), RR Dist, Near Ramoji Film City, Hyderabad -501512.

www.aietg.ac.in email: principal.avanthi@gmail.com

2.5.1 Mechanism of Internal/External assessment is transparent and the grievance redressal system is time-bound and efficient.

S. No	Description	Page No
1	Mechanism of Internal/External Examination Redressal Grievance	3-5
2	Internal Assessment	----
	1. Mid Exams	----
	1.1 Mid Circulars	6-12
	1.2 Mid Time Tables	13
	1.2 Question Paper	14
	1.3 Scheme of Evaluation	15
	1.4 Answer Script	16-21
	1.5 Objective paper	22
	2. Sample Assignment	23-29
	3. Lab Internal Exam	----
	3.1 Question Paper	30
	3.2 Scheme of Evaluation	31
	3.3 Answer script	32-39
	3.4 Record	40-42
	4. Consolidated Marks	43-44
	5. Display of marks	45
	6. Major project Details	46
	7. Major project Internal Marks	47
	8. Major project External marks	48
9. Major Project certificate	49-51	
3	1. External Assessment	----
	1. External lab Exam	----
	1.2 External lab Circulars	52
	1.1 External lab Examiners	53
	1.2 Question Paper	54
	1.3 External lab Schedule	55
	1.4 External lab Scheme of Evaluation	56
	1.5 External Lab Script	57-61
	1.6 External Lab Relieving Letters	62-64
	2. External Theory Exam	----
	2.1 Observer List	65
	2.2 Blank Answer Script	66
	2.3 External Evaluators List	67-68
	2.4 PC and Consolidated Marks Memo	69-70
	2.5 External Exam blank Script	71
	3. External Project Exam	----

(Handwritten Signature)

PRINCIPAL

Avanathi Institute of Engineering and Technology

Gunthapally (V), Abdullapurmet (Mdl), R.R. Dist.



AVANTHI INSTITUTE OF ENGINEERING AND TECHNOLOGY

(Approved by AICTE, Regd. By Govt. of T.S & Affiliated to JNTUH, Hyderabad)

NAAC "B++" Accredited Institute

Gunthapally (V), Abdullapurmet(M), RR Dist, Near Ramoji Film City, Hyderabad -501512.

www.aietg.ac.in email: principal.avanthi@gmail.com

	3.1 External Examiners given by JNTUH	72-73
4	External Grievances	74-136
5	Internal Grievances	137-143
6	Complaints	144-160

PRINCIPAL

PRINCIPAL

Avanthi Institute of Engineering and Technology
Gunthapally (V), Abdullapurmet(M), R.R. Dist.



AVANTHI INSTITUTE OF ENGINEERING AND TECHNOLOGY

(Approved by AICTE, Recg. By Govt. of T.S & Affiliated to JNTUH, Hyderabad)

NAAC "B++" Accredited Institute

Gunthapally (V), Abdullapurmet(M), RR Dist, Near Ramoji Film City, Hyderabad -501512.

www.aietg.ac.in email: principal.avanathi@gmail.com

Mechanism for Internal Examination Grievance Redressal: The College has a well organized mechanism for Redressal of examination related grievances. The students can approach the faculty members, the concerned HOD and the Principal to redress the examination related grievances. The institution follows the University policy regarding the conduct of Examinations. The entire mechanism to deal with examination related grievances is time bound as per the University rules and regulations.

Procedure of Internal Examination:

- At the beginning of the semester, faculty members will inform the students about the various components in the assessment process during the semester as per the time-tables issued by JNTUH kukatpally.
- Time tables of both Examinations will be circulated to all HODS and Faculty members.
- The same time tables will be circulated to all the students and also displayed on the College, Notice Board.
- The internal assessment test schedules are prepared as per the university norms and communicated to the students well in advance.
- To ensure proper conduct of formative tests, two invigilators are assigned to each hall.
- Evaluation is done by the course handling faculty members and is informed to submit the evaluated answer scripts within three days from the date of conduct of examination.
- The corrected answer scripts are distributed to the students for their verification and in case of any grievances, steps are also taken to resolve it immediately.
- The marks obtained by the students in internal assessment tests are displayed on the department notice board.
- After that the marks are uploaded periodically on the university web portal along with their attendance.
- Day to day performance of the students is assessed for every experiment which includes regularity, viva and the promptness in submitting the record. For the quality of the projects, the evaluation is done by Project Review Committee along with project guides.

PRINCIPAL

Avanathi Institute of Engg. & Tech
Gunthapally (V), Abdullapurmet (M), R.R. Dist.

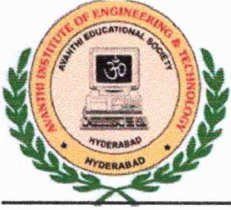

AVANTHI INSTITUTE OF ENGINEERING AND TECHNOLOGY

(Approved by AICTE, Recg. By Govt. of T.S & Affiliated to JNTUH, Hyderabad)

NAAC "B++" Accredited Institute

Gunthapally (V), Abdullapurmet(M), RR Dist, Near Ramoji Film City, Hyderabad -501512.

www.aietg.ac.in email: principal.avanthi@gmail.com

Redressal of Grievances related to Internal Examination (College level):

- After the Mid Exam evaluation, the descriptive answer scripts will be distributed to the students for verification.
- In case of any corrections, the student will take it to the notice of the concerned faculty.
- The concerned faculty will re-evaluate the answer script based on the scheme of evaluation and if no difference in marks is identified, the same will be communicated to the student by explaining the scheme of evaluation. If any difference in marks is noticed, the faculty will modify the marks.
- More than 90% of the issues will be resolved at the faculty level.
- In case the problem is not resolved by the faculty/or if the student is not satisfied, the same would be taken to the notice of concerned HOD.
- The HOD would handle such grievances by assigning the related sheets (question paper, scheme of evaluation, answer script) to the another subject expert for immediate revaluation.
- After revaluation if there is no change in the marks, the same would be communicated to the student(s).
- In case of any difference in marks, the concerned HOD will inform to the subject faculty to update the marks.
- The Mid marks are allotted based on defined strategies and displayed on notice board.

Mechanism for External Examination Grievance Redressal:

The college has a well organized mechanism for Redressal of examination related grievances. All the discrepancies regarding examination, faced by the college is immediately brought to the notice of the Controller of Examination of the University and corrections if any are done only after getting instructions from the University. It is very transparent and time bound.

Procedure of External Examination:

- The End Examination for the laboratory and projects shall be conducted with External examiner appointed from the other colleges as decided by the University.
- The Examination Cell will prepare the invigilation chart for Faculty and seating plan arrangement for the students with internal jumbling mechanism based on the time tables.
- Invigilators shall make announcement in the Examination hall about the rules regarding the conduct of Examinations including the prohibition of electronic devices by the students in the Examination hall.
- The invigilators are expected to be tactful while dealing with complex situations and not to disturb the tranquility in the exam hall.

PRINCIPAL

Avanthi Institute of Engineering and Technology

Avanthi Institute of Engg. & Tech
Gunthapally (V), Abdullapurmet (M), R.R. Dist.



AVANTHI INSTITUTE OF ENGINEERING AND TECHNOLOGY

(Approved by AICTE, Recg. By Govt. of T.S & Affiliated to JNTUH, Hyderabad)

NAAC "B++" Accredited Institute

Gunthapally (V), Abdullapurmet(M), RR Dist, Near Ramoji Film City, Hyderabad -501512.

www.aietg.ac.in email: principal.avanathi@gmail.com

- In case any problem is identified, he/she may bring the matter to the notice of the Chief Superintendent and depending on the seriousness of the issue, the same can/could be taken to Controller of the Examinations (CoE).
- Generally, scheduled forenoon session Examinations starts at 10.00 AM and afternoon session Examinations starts at 2.00 PM.
- Invigilators were informed to arrive at the respective examination halls at least 30 minutes before the commencement of the Examination.
- All invigilators appointed in a hall are informed to report back in the Examination Cell after the completion of examination and are solely responsible for the submission of the answer booklets to the concerned Examination Cell authorities.
- Invigilators were informed to report immediately to the Chief Superintendent if any unusual incidents identified/traced during the examinations.
- As per the University regulations, our students are allotted other institutions as exam centers and our college is allotted as centre for other Institutions.
- External examiners for labs & Project Viva will be appointed from university.
- Our faculty members will be relieved for exam duties as Observer, external examiner for other institutions as per the slots provided by the University.
- Our faculty members will be relieved for Spot valuation for paper corrections & Scrutiny as per the slots given by the University.

Redressal of grievances related to External Examinations (University level):

The queries related to results, corrections in mark sheets issued by the University are handled at JNTU-H Examination Cell after forwarding such queries through the college Examination Cell. If the students are not satisfied with the marks evaluated by the University, the students are allowed to apply for Revaluation, Recounting and Challenged Evaluation by paying the necessary processing fee to the University. For students whose marks are not entered or incorrectly entered, the college sends a photocopy of the mark list with an application to rectify the error at the University level. Thus the college is prompt and takes utmost care in handling any Grievances of the student(s).

PRINCIPAL

Avanathi Institute of Enng. & Tech

Gunthapally (V), Abdullapurmet (M), R.R. Dist.



AVANTHI INSTITUTE OF ENGINEERING AND TECHNOLOGY

(Approved by AICTE, Regg. By Govt. of T.S & Affiliated to JNTUH, Hyderabad)

NAAC "B++" Accredited Institute

Gunthapally (V), Abdullapurmet(M), RR Dist, Near Ramoji Film City, Hyderabad -501512.

www.aietg.ac.in email: principal.avanthi@gmail.com

Mid Circulars

Cir./Exam Section/0001

Date: 02-05-2022

Attention all the I B.TECH I SEM students are here by informing you that MID-II examinations will be conducted from 06-05-2022 to 07-05-2022.

Time: FN: 09.40 AM TO 11.00 AM

AN: 01.40 PM TO 03.00 PM

OIE

PRINCIPAL

Copy to: 1. HOD – H&S

2. Administrative Office

3. Notice Boards

PRINCIPAL
Avanathi Institute of Engg. & Tech
Gunthapally (V), Abdullapurmet (M), R.R. Dist.



AVANTHI INSTITUTE OF ENGINEERING AND TECHNOLOGY

(Approved by AICTE, Recg. By Govt. of T.S & Affiliated to JNTUH, Hyderabad)

NAAC "B++" Accredited Institute

Gunthapally (V), Abdullapurmet(M), RR Dist, Near Ramoji Film City, Hyderabad -501512.

www.aietg.ac.in email: principal.avanathi@gmail.com

Cir./Exam Section/0002

Date: 26-05-2022

Attention all the II B.TECH II SEM students are here by informing you that MID-I examinations will be conducted from 31-05-2022 to 03-06-2022.

Time: FN: 09.40 AM TO 11.00 AM

AN: 01.40 PM TO 03.00 PM

OIE

PRINCIPAL

Copy to: 1. ALL HOD's (EEE, MECH, ECE, and CSE)

2. Administrative Office

3. Notice Boards

PRINCIPAL

Avanathi Institute of Engg. & Tech
Gunthapally (V), Abdullapurmet (M), R.R. Dist.



AVANTHI INSTITUTE OF ENGINEERING AND TECHNOLOGY

(Approved by AICTE, Recg. By Govt. of T.S & Affiliated to JNTUH, Hyderabad)

NAAC "B++" Accredited Institute

Gunthapally (V), Abdullapurmet(M), RR Dist, Near Ramoji Film City, Hyderabad -501512.

www.aietg.ac.in email: principal.avanthi@gmail.com

Cir./Exam Section/0003

Date: 06-07-2022

Attention all the III, IV B.TECH II SEM students are here by informing you that MID-II examinations will be conducted from 11-07-2022 to 16-07-2022.

Time: FN: 09.40 AM TO 11.00 AM

AN: 01.40 PM TO 03.00 PM

OIE

PRINCIPAL

Copy to: 1. ALL HOD's (EEE, MECH, ECE and CSE)

2. Administrative Office

3. Notice Boards

PRINCIPAL

Avanthi Institute of Engg. & Tech
Gunthapally (V), Abdullapurmet (M), R.R. Dist

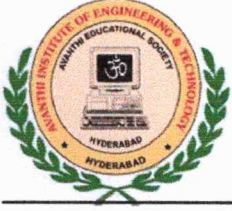

AVANTHI INSTITUTE OF ENGINEERING AND TECHNOLOGY

(Approved by AICTE, Recg. By Govt. of T.S & Affiliated to JNTUH, Hyderabad)

NAAC "B++" Accredited Institute

Gunthapally (V), Abdullapurmet(M), RR Dist, Near Ramoji Film City, Hyderabad -501512.

www.aietg.ac.in email: principal.avanthi@gmail.com

Cir./Exam Section/0004

Date: 06-08-2022

Attention all the II B.TECH II SEM students are here by informing you those MID-II examinations will be conducted from 10-08-2022 to 12-08-2022.

Time: FN: 09.40 AM TO 11.00 AM

AN: 01.40 PM TO 03.00 PM

OIE

PRINCIPAL

Copy to: 1. ALL HOD's (EEE, MECH, ECE and CSE)

2. Administrative Office

3. Notice Boards

PRINCIPAL
Avanthi Institute of Engg. & Tech
Gunthapally (V), Abdullapurmet (M), R.R. Dist.



AVANTHI INSTITUTE OF ENGINEERING AND TECHNOLOGY

(Approved by AICTE, Recg. By Govt. of T.S & Affiliated to JNTUH, Hyderabad)

NAAC "B++" Accredited Institute

Gunthapally (V), Abdullapurmet(M), RR Dist, Near Ramoji Film City, Hyderabad -501512.

www.aietg.ac.in email: principal.avanthi@gmail.com

Cir./Exam Section/0005

Date: 10-08-2022

Attention all the I B.TECH II SEM students are here by informing you that MID-I examinations will be conducted from 16-08-2022 to 17-08-2022.

Time: FN: 09.40 AM TO 11.00 AM

AN: 01.40 PM TO 03.00 PM

OIE

PRINCIPAL

Copy to: 1. HOD – H&S

2. Administrative Office

3. Notice Boards

PRINCIPAL
Avanthi Institute of Engg. & Tech
Gunthapally (V), Abdullapurmet (M), R.R. Dist.



AVANTHI INSTITUTE OF ENGINEERING AND TECHNOLOGY

(Approved by AICTE, Reg. By Govt. of T.S & Affiliated to JNTUH, Hyderabad)

NAAC "B++" Accredited Institute

Gunthapally (V), Abdullapurmet(M), RR Dist, Near Ramoji Film City, Hyderabad -501512.

www.aietg.ac.in email: principal.avanthi@gmail.com

Cir./Exam Section/0006

Date: 27-10-2022

Attention all the I B.TECH II SEM students are here by informing you that MID-II examinations will be conducted from 01-11-2022 to 02-11-2022.

Time: FN: 09.40 AM TO 11.00 AM

AN: 01.40 PM TO 03.00 PM

OIE

PRINCIPAL

Copy to: 1. HOD – H&S

2. Administrative Office

3. Notice Boards

PRINCIPAL
Avanathi Institute of Engg. & Tech
Gunthapally (V), Abdullapurmet (M), R.R. Dist.



AVANTHI INSTITUTE OF ENGINEERING AND TECHNOLOGY

(Approved by AICTE, Recg. By Govt. of T.S & Affiliated to JNTUH, Hyderabad)

NAAC "B++" Accredited Institute

Gunthapally (V), Abdullapurmet(M), RR Dist, Near Ramoji Film City, Hyderabad -501512.

www.aietg.ac.in email: principal.avanthi@gmail.com

Cir./Exam Section/0007

Date: 26-04-2022

Attention all the III, IV B.TECH II SEM students are here by informing you that MID-I examinations will be conducted from 02-05-2022 to 06-05-2022.

Time: FN: 09.40 AM TO 11.00 AM

AN: 01.40 PM TO 03.00 PM

OIE

PRINCIPAL

Copy to: 1. ALL HOD's (EEE, MECH, ECE and CSE)

2. Administrative Office

3. Notice Boards

PRINCIPAL
Avanthi Institute of Engg. & Tech
Gunthapally (V), Abdullapurmet (M), R.R. Dist.



AVANTHI INSTITUTE OF ENGINEERING AND TECHNOLOGY

(Approved by AICTE, Regd. By Govt. of T.S & Affiliated to JNTUH, Hyderabad)

NAAC "B++" Accredited Institute

Gunthapally (V), Abdullapurmet(M), RR Dist, Near Ramoji Film City, Hyderabad -501512.

www.aietg.ac.in email: principal.avanathi@gmail.com

DEPARTMENT OF MECHANICAL ENGINEERING 2022-23

YEAR/SEM/SEC: I/II/A

II MID SEATING PLAN

EXAM TIME: 09:40AM To 11:00AM

Exam Dates From: 21-08--2023 to 26-08-2023.

01:40PM To 03:00pm

S.NO	ROOM NO	YEAR	FROM	TO	NO OF STUDENTS	TOTAL
1	B-403	I-II	22Q61A0301	22Q61A0324	24	24
2	B-404	I-II	22Q61A0325	22Q61A0340	16	16

HOD

PRINCIPAL

PRINCIPAL
Avanathi Institute of Engg. & Tech
Gunthapally (V), Abdullapurmet (M), R.R. Dist.



AVANTHI INSTITUTE OF ENGINEERING AND TECHNOLOGY

(Approved by AICTE, Recg. By Govt. of T.S & Affiliated to JNTUH, Hyderabad)

NAAC "B++" Accredited Institute

Gunthapally (V), Abdullapurmet(M), RR Dist, Near Ramoji Film City, Hyderabad -501512.

www.aictg.ac.in email: principal.avanathi@gmail.com

DEPARTMENT OF MECHANICAL ENGINEERING

III B.TECH II Semester I-MID Examination(R 18, MAY-2023)

Name of the Subject: Fundamentals of Management

Subject code: CS601OE

Time: 1 Hour

Branch: Mechanical

Max. Marks: 10

Date of Exam: 31/05/2023

SET-I

PART-A

Answer all the Questions and each question carries equal marks

4x1=4

1. Define Management.
2. Write some Technical skills.
3. Write about Creativity and Innovation.
4. What are the Managerial roles?

PART-B

2x3=6

1. Explain the functions of the Management.
- OR**
2. Explain the System approach to Management?
 3. What is mean by Organization chart? Explain it.
- OR**
4. Explain about HR Management.

PRINCIPAL
Avanathi Institute of Engg. & Tech
Gunthapally (V), Abdullapurmet (M), R.R. Dist.



AVANTHI INSTITUTE OF ENGINEERING AND TECHNOLOGY

(Approved by AICTE, Regd. By Govt. of T.S & Affiliated to JNTUH, Hyderabad)

NAAC "B++" Accredited Institute

Gunthapally (V), Abdullapurmet(M), RR Dist, Near Ramoji Film City, Hyderabad -501512.

www.aietg.ac.in email: principal.avanthi@gmail.com

III B.TECH II Semester I-MID Examination(R 18, MAY-2023)

Scheme of Evaluation

Name of the Subject: Fundamentals of Management

Subject code:CS601OE

Time: 1 Hour

Branch: Mechanical

Max. Marks: 10

PART-A

1. Define Management.
Defination-1m
2. Write some Technical skills.
Any four points-1m
3. Write about Creativity and Innovation.
Explanation of creativity -1/2m
Explanation of Innovation-1/2 m
4. What are the Managerial roles?
Any five points-1m

PART-B

1. Explain the functions of the Management.
Any 10 functions-2m
Line diagram-1m
2. Explain the System approach to Management?
Explanation-2m
Example-1m
3. What is mean by Organization chart? Explain it.
Explanation-1m
Diagram-1m
Example-1m
4. Explain about HR Management.
Explanation-2m
Application-1m

PRINCIPAL
Avanthi Institute of Engg. & Tech
Gunthapally (V), Abdullapurmet (M), R.R. Dist.

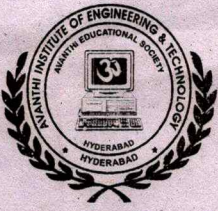

AVANTHI INSTITUTE OF ENGINEERING & TECHNOLOGY

(Approved by AICTE, Recognised by Govt. of T.S., & Affiliated to JNTU, Hyderabad)
Gunthapally (V), Abdullapurmet (M), R.R. Dist., Near Ramoji Filmcity, Hyderabad - 501 512.

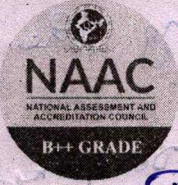

INTERNAL DISSCRIPTIVE EXAM



NAME: P. Siddhu Kalyan

7/10

8/10

DATE: 31/05/2023

ROLL No: 21065A0303

Subject: FOM

CLASS: B.Tech 3rd Year SEM 2nd

SIGNATURE OF THE INVIGILATOR'S: Sh

SIGNATURE OF THE STUDENT: P. Siddhu Kalyan

TOTAL MARKS:

① PART-B functions of Management

The following are the functions of management

- Planning
- Organizing
- Staffing
- Controlling
- Motivating
- Decision making
- Evaluating
- ~~Administration~~
- Administrations And Policies.

Planning: Planning is the concrete one, determination of future course of action to achieve the desired result.

Organising:

It is the process of dividing the work into current task or duties grouping of such of positions.

Grouping of various positions is to be departments and sections assigning duties to individual authority.

Staffing:

It is planning the various positions created by the organising process training them and accented to do the work as per the requirements of the job role.

Controlling:

It involves identifying the future results in considering now and comparison of actual with expected results.

It controls the each and every workers and to do the work what requires to them that should we submitted to them and completing the work.

Decision making

Decision-making means choosing the best option among different choices based on a set of goals or criteria.

It involves carefully analyzing each option considering its advantages and disadvantages and then selecting and doing that which is most likely to help achieve the desired outcomes.

Evaluating

Evaluation is the analysis and comparison of actual progress vis-à-vis prior plans. Evaluation is oriented toward improving plans for future implementation to ensure improved performance.

Administrative

→ focused on what managers do

→ Managerial functions (Henly Fayol)

- planning, organizing
- Coordinating, Commanding
- Controlling

→ Managerial Roles

- Interpersonal
- Informational

PRINCIPAL

Avanthi Institute of Engg. & Tech.
Guntur (V), Abdullapurmet (Mdl), R.R. Dist.

Administrative management is the process of managing information through people. This usually involves performing the storage and distribution of information to those within an organization.

③

① Organization chart levels

→ Relative Position

→ Inter Relationship

→ Relationship between different managers

→ Nature of managerial relationship

→ Span of Control

→ Acts a guide for expansion

→ Responsible position for an activity

→ Helps in Improving the structure

Features of organization of chart levels

* It is the most simplest form of

organization

* Line of frame form to bottom

* Specified and Supportive Services

* Untrilled control is the line effect can

be maintained since the can be maintained

Since the can be Independent in their.

⑧ The entire entire organizational activities are divided into specific functions such as Operations.

⑨ Expert knowledge of functional manager

facilitates better control and supervision.

PART-A

① a. Management:

It means managing the work with the division of department in an organization with the support of the H.R & CEO. Then it is called as Management.

b. Technical Skills:

The skills which is purely based on the technology related to the branch which is used in the feature (a) To develop the machine (b) To update it is called as Technical Skills.

c.

Creativity: it is based on the thinking capacity of an human to create a new (a) updating the features and use of an machine called Creativity.

Innovation: By using the creativity thinking capacity introducing a new device ^(or) a machine then it is called Innovation.

① Managerial Roles:

~~The Roles which are maintained and followed by the workers and the entire company is called as Managerial Roles.~~
→ Team Working.

Branch: MECH

Set No: 1



AVANTHI INSTITUTE OF ENGINEERING AND TECHNOLOGY
III B.Tech. II Sem. I Mid-Term Examinations, May - 2023
FUNDAMENTALS OF MANAGEMENT FOR ENGINEERS

Time: 20

Max. Marks: 10

Name: P. Siddhu Kalyan Hall Ticket No: 21065A0302

Answer All Questions. All Questions Carry Equal Marks.

I Choose the correct alternative:

1. Management means _____ [D]
A) doing things B) completing things C) getting things done by others D) all
2. Management is _____ [D]
A) a profession B) multidisciplinary C) science and art D) all
3. which of the following are the management functions [C]
A) planning & organizing B) staffing, directing & controlling C) both a and b D) none
4. who among the following decides objectives and goals [A]
A) Top management B) middle management C) lower level management D) all
5. who among the following requires all the skills equally [B]
A) Top management B) middle management C) lower level management D) all
6. span of control means _____ under control [A]
A) No of employees B) area C) Length of the room D) all
7. Gossip is an example for _____ organization [B]
A) formal B) informal C) neither a nor b D) either a or b
8. which of the following is a combination of line and staff organization [A]
A) functional B) military C) matrix D) committee
9. the worth of the job is explained in [C]
A) job description B) job specification C) job evaluation D) job analysis
10. what an employee must do and what are his responsibilities is explained in [B]
A) job description B) job specification C) job evaluation D) job analysis

Set No: 1

II Fill in the blanks

11. Planning means the function of management that involves setting objectives and determining a course of action for achieving those objectives
12. Budget explains about oversight of revenue and expenditure tracking in an organization
13. Scholarly articles is recentralization
14. Unity of command means one mission one boss.
15. Operational planning is done by a team
16. KRAs means Key Result Areas
17. Apprentice training is technical vocational education and training type of training
18. the underlying beliefs, assumptions, values and ways of interacting of an organization is Culture
19. transferring authority from the top level to the lower level is decentralization
20. The hierarchy of an organization is indicated by to range diagram.

PRINCIPAL
Avanthi Institute of Engg. & Tech.
Guntur, G. O. Abdullapuram (M), G. R. Dist.

ENGINEERING
MECHANICS
ASSIGNMENT
II

Name :- G. Vignesh

Roll No :- 21Q65A0213

Standard :- 2nd year, 1st Sem, B. Tech

College :- AVIH, Guntapally.



PRINCIPAL
Avanthi Institute of Engg. & Tech.
Gunthapally (V), Abdullapurmet (Mdl), R.R. Dist.

1. Derive the moment of Inertia of Rectangle, triangle and circle with respect to References and centroidal axis.

Ans:

1. MOMENT OF INERTIA OF A RECTANGLE :-

Consider a Rectangle of length (b), width (d) is represented along two dimensional axis as shown in below fig. Let assume a small Rectangular element inside the Rectangle which is at a distance of y from x -axis and width dy as shown in fig.

Area of small Rectangular element.

$$dA = b(dy)$$

w.r.t x -axis :-

$$I_x = \int y^2 b dy$$

$$= b \left[\frac{y^3}{3} \right]_0^d$$

$$I_x = \frac{bd^3}{3}$$

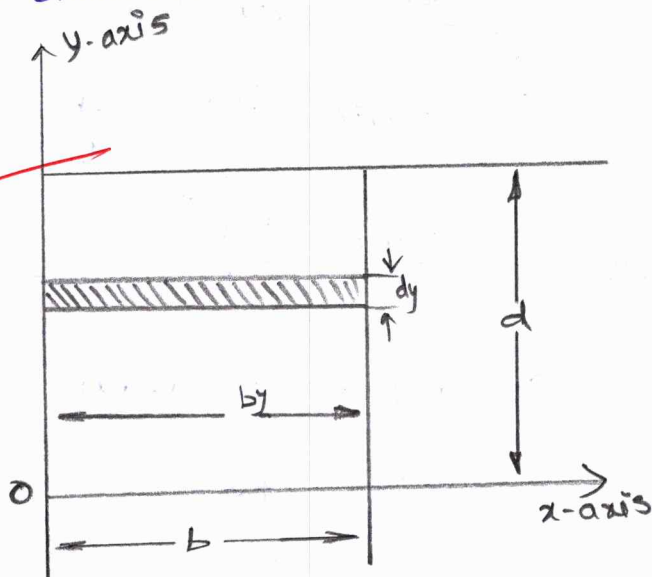

Figure

w.r.t y -axis :-

Area of small element, $dA = d(dx)$

$$I_y = \int x^2 dA$$

$$I_y = \int_0^b x^2 dx$$

APR
PRINCIPAL
 Avanthi Institute of Engg. & Tech
 Gunthapally (V), Abdullapurmet, (Mdl), R.R. Dist.

$$I_y = d \left[\frac{x^3}{3} \right]_0^b$$

$$I_y = \frac{db^3}{3}$$

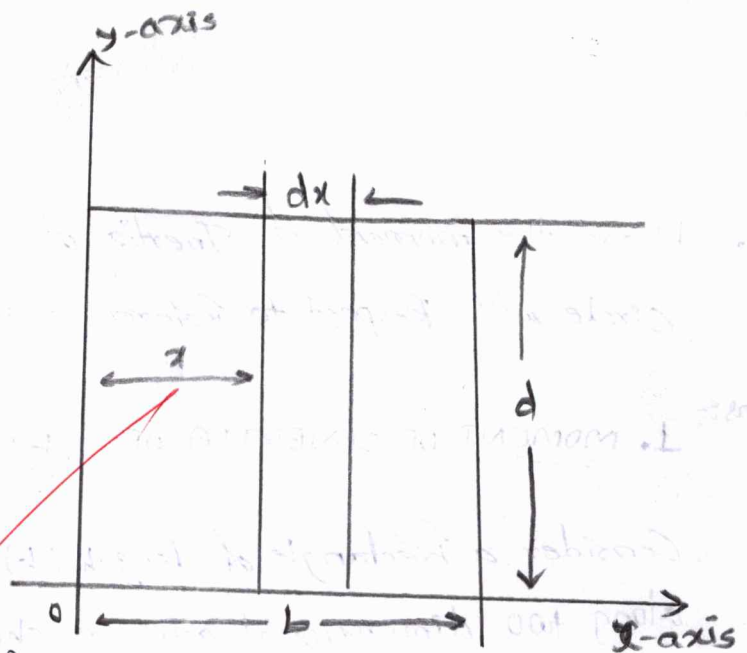

By Parallel axis Theorem :-

with respect to x-axis

Figure

$$I_x = I_{x\bar{x}} + Ay_c^2$$

$$\Rightarrow \frac{bd^3}{3} = I_{x\bar{x}} + bd \left(\frac{d}{2} \right)^2$$

$$\Rightarrow I_{x\bar{x}} = \frac{bd^3}{3} - \frac{bd^3}{4}$$

$$I_{x\bar{x}} = \frac{bd^3}{12}$$

Similarly w.r. to y-axis :-

$$I_{y\bar{y}} = \frac{db^3}{12}$$

2. Moment of a Triangle :-

Consider a triangle of base 'b' and height 'h' represented along horizontal x-axis and vertical y-axis to determine moment of inertia of a triangle. Let assumed a small rectangular element of length 'h' and width 'dy' which is at a perpendicular distance of 'x, y' w.r.t y and x-axis as shown in fig

Area of Rectang Triangle element, $dA = b, dy$

We know that $I_x = \int y^2 dA$
 $= \int_0^h y^2 b, dy$

Assume two Δ s are similar by Properties of Similar triangles.

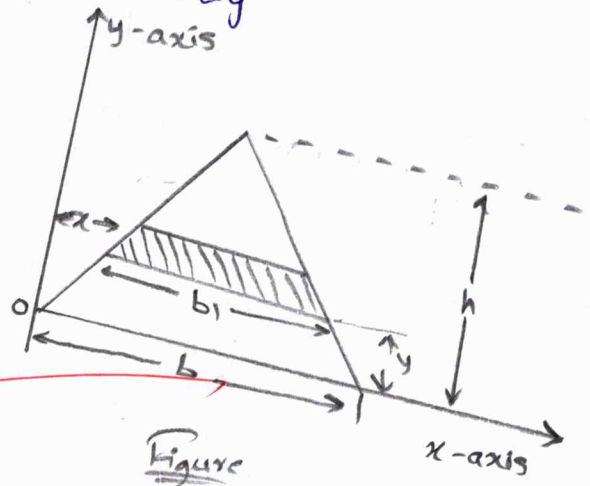

$\Rightarrow \frac{b_1}{h-y} = \frac{b}{h}$

$b_1 = \frac{b}{h} (h-y)$

$\therefore I_x = \int_0^h y^2 \frac{b}{h} (h-y) dy$

$I_x = b \left[\frac{y^3}{3} - \frac{y^4}{4} \right]_0^h$

$I_x = b \left[\frac{h^3}{3} - \frac{h^4}{4h} \right]$

$I_x = b \left[\frac{4h^3 - 3h^3}{12} \right]$

$I_x = \frac{bh^3}{12}$, Similarly

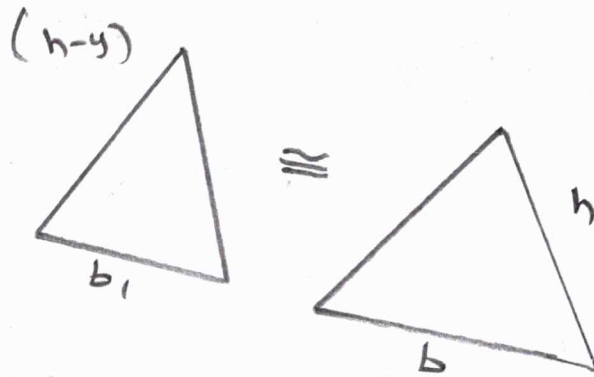

By Properties of Δ s $b_1 d(h-y)$
 $b \times h$

$I_y = \frac{hb^3}{12}$

Handwritten signature

3. Moment of Inertia of a Semi-circle :-
(i)

Consider a Semi-circle of a radius (r) Represented in a co-ordinate System as shown in below figure.

$$I_{\text{Semicircle}} = \frac{1}{2} \times I_{\text{circle}}$$

$$I_{\text{semicircle}} = \frac{\pi D^4 / 64}{2}$$

$$I_{\text{semicircle}} = \frac{\pi D^4}{128}$$

$$I_x = \frac{\pi D^4}{128} \text{ (or) } \frac{\pi R^4}{8}$$

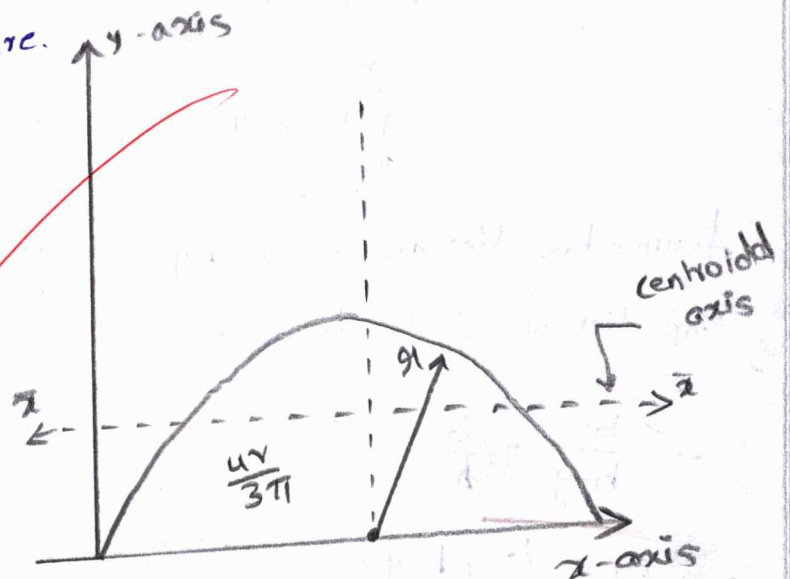

By Parallel axis Theorem :-

$$\Rightarrow I_x = I_{x\bar{x}} + Ay_c^2$$

$$\therefore I_x = \frac{\pi R^4}{8} \text{ [M.I of Semi circle]}$$

$$\Rightarrow \frac{\pi r^4}{8} = I_{x\bar{x}} + \frac{\pi r^2}{2} \left[\frac{4r}{3\pi} \right]^2$$

$$\Rightarrow I_{x\bar{x}} = \frac{\pi r^4}{8} - \frac{\pi r^2}{2} \cdot \left(\frac{16r^2}{9\pi^2} \right)$$

$$\Rightarrow I_{x\bar{x}} = r^4 \left[\frac{\pi}{8} - \frac{8}{9\pi} \right]$$

$$\rightarrow \boxed{I_{x\bar{x}} = 0.11 r^4}$$

(ii) Moment of a Quarter circle :-

Consider a Quarter circle of radius (r) represented in a Co-ordinate system as shown in below figure

$$I_{\text{Quarter circle}} = \frac{1}{4} \times I_{\text{circle}}$$

$$I_{\text{(Q-circle)}} = \frac{1}{4} \times (I_{\text{circle}}) \times$$

$$I_{\text{Quarter circle}} = \frac{1}{4} \times \frac{\pi R^4}{4}$$

$$I_{\text{Quarter circle}} = \frac{\pi r^4}{16} \text{ (or)} \frac{\pi d^4}{256}$$

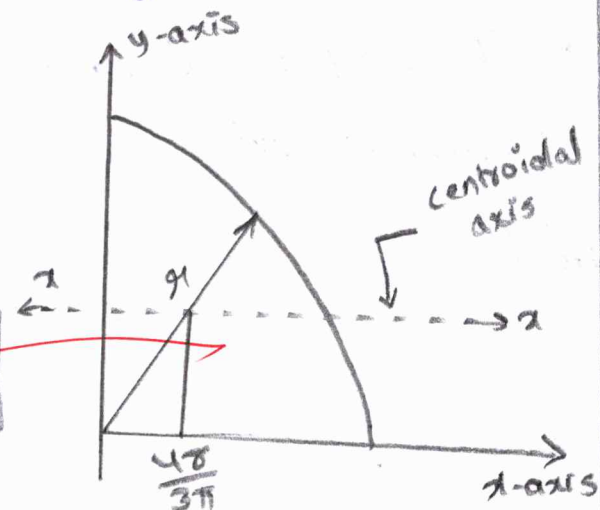

By Parallel-axis Theorem :-

$$I_x = I_{x\bar{x}} + A y_c^2$$

$$\therefore I_x = \frac{\pi r^4}{16}$$

$$\frac{\pi r^4}{16} = I_{x\bar{x}} + \frac{\pi r^2}{4} \left(\frac{4r}{3\pi} \right)^2$$

$$I_{x\bar{x}} = \frac{\pi r^4}{16} - \frac{\pi r^2}{4} \left[\frac{16 r^2}{9 \pi^2} \right]$$

$$I_{x\bar{x}} = r^4 \left[\frac{\pi}{16} - \frac{4}{9\pi} \right]$$

$$I_{x\bar{x}} = 0.055 r^4$$

Signature
PRINCIPAL
Avanthi Institute of Engg. & Tech
Gunthapally (V), Abdullapurmet (Mdl), R.R. Dist.

2. State and Prove that parallel axis theorem :-

Sol: Statement :- The moment of Inertia about any references axis is equal to the algebraic sum of the moment of Inertia about it's centroidal axis and product of Area of the body and distance between the body and the References axis.

Proof :-

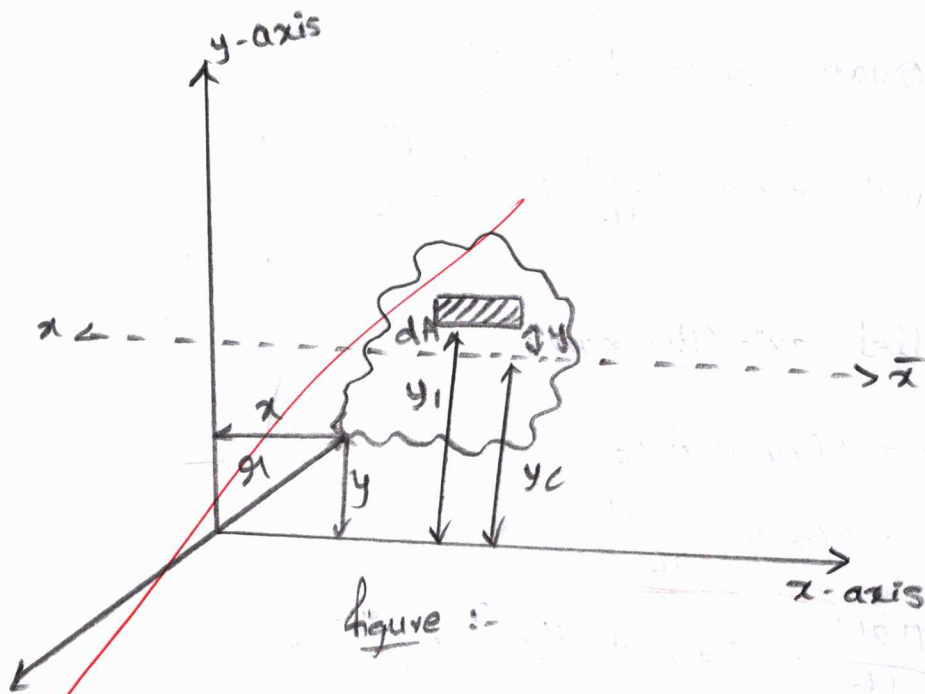

w.r.to x-axis :-

$$I_x = \int y^2 dA$$

$$I_x = \int (y + y_c)^2 dA$$

$$I_x = I_{x\bar{x}} + \int y_c^2 dA + 2 \int y \cdot y_c dA$$

$$I_x = I_{x\bar{x}} + A y_c^2$$

Similarly w.r.to y-axis

$$I_y = I_{y\bar{y}} + A x_c^2$$

Since the first moment of inertia about it's about centroidal axis is zero so $\int y \cdot y_c dA$ is zero.

5/5

PRINCIPAL

Engg. & Tech
Gurukul (Mdl), R.R. Dist.

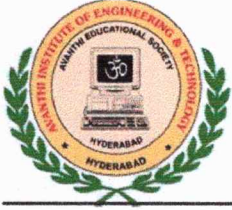

AVANTHI INSTITUTE OF ENGINEERING AND TECHNOLOGY

(Approved by AICTE, Regg. By Govt. of T.S & Affiliated to JNTUH, Hyderabad)

NAAC "B++" Accredited Institute

Gunthapally (V), Abdullapurmet(M), RR Dist, Near Ramoji Film City, Hyderabad -501512.

www.aietg.ac.in email: principal.avanthi@gmail.com

III-II LAB INTERNAL EXAMINATIONS - 2023

Sub: **Heat Transfer**

Branch: **Mechanical**

Date: **30-07-22**

Session: **FN/AN**

1. Calculate Overall heat transfer co-efficient of a composite wall.
2. Calculate Thermal conductivity and Heat transfer through lagged pipe.
3. Calculate thermal conductivity of a Concentric Sphere.
4. Thermal Conductivity of given metal rod.
5. Calculate Effectiveness and Efficiency of pin-fin apparatus.
6. Calculate Heat Transfer co-efficient in Transient Heat Conduction apparatus.
7. Calculate heat transfer co-efficient in forced convection apparatus.
8. Calculate heat transfer co-efficient in natural convection.
9. Calculate Effectiveness in Parallel and counter flow heat exchanger.
10. Find Emissivity of a given apparatus.
11. Calculate Stefan Boltzman value of a given Apparatus.
12. Calculate Critical Heat flux value of a given apparatus.
13. Study of heat pipe and its demonstration.
14. Demonstration Film and Drop wise condensation apparatus.

Signature of the Internal Examiner

Signature of the HOD

PRINCIPAL
Avanthi Institute of Engg. & Tech
Gunthapally (V), Abdullapurmet (M), R.R. Dist.



AVANTHI INSTITUTE OF ENGINEERING AND TECHNOLOGY

(Approved by AICTE, Recg. By Govt. of T.S & Affiliated to JNTUH, Hyderabad)

NAAC "B++" Accredited Institute

Gunthapally (V), Abdullapurmet(M), RR Dist, Near Ramoji Film City, Hyderabad -501512.

www.aietg.ac.in email: principal.avanathi@gmail.com

III B. Tech II Semester Lab Internal Examinations –R18

Scheme of Evaluation

S.NO	EVALUTION PROCESS	MARKS
1	Internal Lab Exam	10M
2	Day Today Work	5M
3	Record	5M
4	Viva	5M



Signature of the Faculty

PRINCIPAL
Avanathi Institute of Engg. & Tech
Gunthapally (V), Abdullapurmet (M), R.R. Dist.

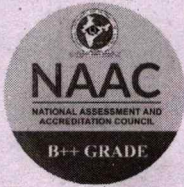

AVANTHI INSTITUTE OF ENGINEERING & TECHNOLOGY

(Approved by AICTE, Recognised by Govt. of T.S., & Affiliated to JNTU, Hyderabad)
Gunthapally (V), Abdullapurmet (M), R.R. Dist., Near Ramoji Filmcity, Hyderabad - 501 512.



INTERNAL DISCRIPTIVE EXAM



NAME: M. Keerthana

DATE: 30-07-22

ROLL No.: 202265A0303

Subject: Heat transfer Lab - Intern

CLASS: 3rd year SEM: II

SIGNATURE OF THE INVIGILATOR'S: [Signature]

SIGNATURE OF THE STUDENT: M. Keerthana

TOTAL MARKS: 10+5+5+5 [Signature]

Heat transfer by Pin-Fin.

* AIM: To determine the heat transfer by pin fin apparatus.

* Description:

Heat transfer by pin-fin, it having fin which placed inside the closed surface. 12 No's of thermocouples are placed on the surface of the closed body that having thermocouples $T_1, T_2, T_3, T_4, T_5, T_6, T_7, T_8, T_9, T_{10}, T_{11}, T_{12}$ are the thermocouples that are going to finding the efficient of the fin and effectivity of pin-fin.

* specification

Diameter of fin $d_f = 300\text{mm}$

length of fin $l_f = 1500\text{mm}$

thickness of fin = 55 mm

[Signature]
PRINCIPAL
Avanthi Institute of Engg. & Tech
Gunthapally (V), Abdullapurmet (Mdl), R.R. Dist.

T_{∞} = ambient temperature

T_a = initial temperature

Sl. No	I	Y	Temperature T_a				Temperature T_b			Pressure difference		
			T_1	T_2	T_3	T_4	T_5	T_6	P_i	P_o	$P_o - P_i$	
①	83	0140	73	63	54	49	45	34	80	60	20	

PRINCIPAL
 Avanti Institute of Engg. & Tech.
 Dist.

②

* Theory :

$$Re = \frac{uds}{\nu}$$

According to the thermocouples reading T_a and T_b by taking average of that both temperature we can take T_f values that T_f values based we can take the values from data book, that are density, thermal conductivity ' k ', velocity, kinematic viscosity

$$Q = -kA \frac{dT}{dx}$$

$$A = \frac{\pi}{4} d^2 m^2$$

$$D = \frac{d_o}{d_i}$$

$$Re = \frac{ud\rho}{\mu}$$

$$Nu = \frac{hL}{k} \text{ or } \frac{hd}{k}$$

$$h = \frac{kNu}{L}$$

ν_a = Absolute viscosity, Ns/m^2 .

ν_o = Kinematic viscosity ' ν ' m^2/s .

d_o = outer diameter mm

d_i = inner diameter mm

d_f = diameter of pipe mm

Calculations

$$T_{avg} = \frac{T_1 + T_2 + T_3 + T_4 + T_5}{5} = \frac{73 + 63 + 59 + 49 + 45}{5} = 57.8$$

$$T_{avg} = 57.8$$

$$T_{avg} = 63.6$$

$$T_{avg} = 34 + 27.3$$

$$T_{avg} = 34$$

$$A = \frac{\pi}{4} d^2 \cdot m$$

$$A = \frac{\pi}{4} \times 0.05^2 \cdot m$$

$$A = 0.007 m^2$$

$$Re = \frac{u d \rho}{\mu}$$

$$\mu = 20.10 \times 10^{-6}$$

$$\rho = 1000$$

$$v = 18.97 \times 10^{-6}$$

$$\rho = 0.649 \text{ m/s}$$

$$\mu = 0.02896$$

$$Re = \frac{20.10 \times 10^{-6} \times 0.05 \times 1000}{18.97 \times 10^{-6}}$$

$$Re = 909.10 \times 10^3$$

$$Nu = \frac{h L}{k}$$

$$Nu = 0.6 (Pr)^{0.2}$$

$$Nu = 0.6 (0.699)^{0.2}$$

$$Nu = 44.40$$

$$Nu = 44.84$$

$$44.84 = \frac{h \times 115}{110}$$

$$L = 115$$

$$k = 110$$

$$h = 42.84 \text{ W/m}^2\text{C}$$

$$m = \sqrt{\frac{h P}{K A}}$$

$$m = \frac{42.84 \times 0.05}{110 \times 0.07}$$

$$m = 1.55$$

* PROCESS :-

- 1) switch 'ON' electrical power supply.
- 2) Wait for a few mint upto the equipment reached standard temperature.
- 3) Firstly take the reading of current 'I' and voltage 'V'.
- 4) move (or) start the rotation of dimmer starter.
- 5) thermocouple of '12' and dimmer starter should be rotate 12 times.
- 6) Take that all reading which is display in digital machine.
- 7) switch 'off' electrical power.
- 8] Reset the dimmer starter.

* calculations

$$Q = -kA \frac{dT}{dx}$$

- k = thermal conductivity

A = Area of cross section

$$A = \frac{\pi}{4} d^2 \text{ m}^2 \text{ or } \text{mm}^2$$

dT = temperature difference.

$$D = \frac{d_o}{d_i}$$

* diameter of outer surface d_o
 * diameter of inner surface d_i

$$Re = \frac{\rho u s}{\mu}$$

Re = Reynolds Number.

μ = kinematic viscosity

ρ = density

Nu = Nusselt Number

$$Nu = \frac{h d}{k}$$

h = heat transfer coefficient W/m^2C

d = diameter of Fin 'm'

k = thermal conductivity W/m^2C

* Result :

the ~~term~~
Heat transfer from the Pin-Fin $h = 42.89$

* Efficiency of the Fin $\eta_f = 68.96\%$

* Effectiveness of the Fin $\eta = 0.8\%$

Heat transfer 'h' ~~from~~ the Pin Fin 's'.
Findout.

[Red signature]

[Green signature]

PRINCIPAL
PRINCIPAL
Avanathi Institute of Engg. & Tech
Gunthapally (V), Abdullapurmet (Md), R.R. Dist.

[Faint green signature and stamp]

$$* X = 0.005$$

$$L = 115$$

$$M = 155$$

* Efficiency of Fin

$$= \frac{\cosh m(L-X)}{\cosh(m-L)}$$

$$\eta_f = \frac{\cosh(155)(115-0.005)}{\cosh(155-115)}$$

$$\eta_f = 68.96\%$$

Efficiency of Fin

$$\eta_f = 68.96\%$$

* Effectiveness of Fin

$$= \frac{\tanh(mL)}{mL}$$

$$= \frac{\tanh(155 \times 115)}{155 \times 115}$$

$$= 0.8\%$$

PRINCIPAL
Avanthi Institute of Engg. & Tech
Gunthapally (V), Abulapurmet (M), R.R. Dist.

L. S. Srikanth
21065A0315



AVANTHI

INSTITUTE OF ENGINEERING & TECHNOLOGY

(Approved by AICTE & Affiliated to JNTUH)

Certificate

Department of MECHANICAL ENGINEERING

Certified that this is a bonafide record of practical work done by

Mr./Ms. LAKSA SRIKANATH of B.Tech 3rd Year

II Semester with Hall ticket Number 21065A0315 during the year 2022-23

in the Heat transfer laboratory. Number of experiments done 11

Date of submission: (A) 01-07-23

[Signature]
Signature of the Lab In-Charge

Signature of the HOD [Signature]

[Signature]
External Examiner

Head of the Department
Mechanical Department (M), Near Ramoji Filmcity, R.R. Dist.
Gunthapally (V), Abdullapurmet (M),
Ph: 8526033901, 806377979, 9866664631, 9704755516
Gunthapally (Vill), Abdullapur Met (M),
Ranga Reddy District.

[Signature]
PRINCIPAL
Avanathi Institute of Engg. & Tech
Gunthapally (V), Abdullapurmet (M), R.R. Dist.

INDEX

S.I.No.	Expt. No.	Name of Experiment & Description	Date	Sheet No.	Impressions
01		Composite wall apparatus	18/03/23	1-5	Sl 01/04/23
02		Thermal conductivity of Insulating powder	01/09/23	6-9	Sl 01/09/23
03		Emmissivity Measurement of Radiating Surfaces	08/09/23	10-13	Sl 08/09/23
04		Heat transfer by forced convection.	22/09/23	14-17	Sl 13/10/23
05		Heat transfer from pin-fins apparatus	13/05/23	18-21	Sl 20/05/23
06		Heat transfer by Natural convection	27/05/23	22-25	Sl 02/06/23
07		Heat transfer, through Lagged pipe apparatus	20/05/23	26-28	Sl 27/05/23
08		Transient Heat conduction	03/06/23	29-33	Sl 10/06/23
09		parallel flow / counter flow Heat exchange	10/06/23	34-37	Sl 17/06/23
10		STEFAN BOLTZMAN apparatus	17/06/23	38-40	Sl 24/06/23
11		Heat pipe Demonstration.	24-06/23	41-43	Sl 01/07/23

 PRINCIPAL



AVANTHI INSTITUTE OF ENGINEERING AND TECHNOLOGY

(Approved by AICTE, Recg. By Govt. of T.S & Affiliated to JNTUH, Hyderabad)

NAAC "B++" Accredited Institute

Gunthapally (V), Abdullapurmet(M), RR Dist, Near Ramoji Film City, Hyderabad -501512.

www.aietg.ac.in email: principal.avanthi@gmail.com

CONSOLIDATED INTERNAL MARKS SHEET

IV B. TECH I SEM (ACADEMIC YEAR 2022-23) INTERNAL MARKS STATEMENT

Branch/Year: CSE-A/II-I

Subject: Analog and Digital Electronics

Subject code:CS301ES

Faculty: G.Srinivas

S. NO	HT NO	MID-I				MID-II				AVERAGE
		DES-I	OBJ-1	AS-1	SUM-1	DES-2	OBJ-2	AS-2	SUM-2	
1	21Q61A0501	10	10	5	25	10	9	5	24	25
2	21Q61A0503	6	10	5	21	9	9	5	23	22
3	21Q61A0504	8	10	5	22	9	10	5	24	23
4	21Q61A0505	9	9	5	24	9	9	5	23	24
5	21Q61A0506	9	8	5	23	10	9	5	24	24
6	21Q61A0507	4	9	5	17	7	9	5	21	19
7	21Q61A0508	10	9	5	24	10	10	5	25	25
8	21Q61A0509	9	9	5	23	9	9	5	23	23
9	21Q61A0510	7	7	5	19	7	9	5	21	20
10	21Q61A0511	5	7	5	17	AB	AB	5	5	11
11	21Q61A0512	6	8	5	19	9	9	5	23	21
12	21Q61A0513	6	7	5	18	8	9	5	22	20
13	21Q61A0514	5	7	5	17	8	8	5	21	19
14	21Q61A0515	10	8	5	23	10	10	5	25	24
15	21Q61A0516	5	8	5	18	8	9	5	23	21
16	21Q61A0517	9	8	5	22	9	9	5	23	23
17	21Q61A0518	5	7	5	17	8	9	5	22	20
18	21Q61A0519	7	6	5	18	9	8	5	22	20
19	21Q61A0520	4	6	5	15	8	8	5	21	18
20	21Q61A0521	6	5	5	16	8	9	5	22	19
21	21Q61A0522	10	8	5	23	10	9	5	24	24
22	21Q61A0523	6	9	5	20	8	9	5	22	21
23	21Q61A0524	6	9	5	20	8	9	5	22	21
24	21Q61A0525	7	7	5	19	10	9	5	24	22
25	21Q61A0526	2	8	5	15	5	9	5	19	17
26	21Q61A0527	8	6	5	19	10	8	5	23	21
27	21Q61A0528	5	7	5	17	0	9	5	14	16
28	21Q61A0529	10	9	5	24	10	10	5	25	25
29	21Q61A0530	10	9	5	24	9	9	5	23	24
30	21Q61A0531	8	8	5	21	7	9	5	21	21
31	21Q61A0532	8	7	5	20	8	8	5	21	21
32	21Q61A0533	6	9	5	20	9	9	5	23	22
33	21Q61A0534	6	7	5	18	9	9	5	23	21
34	21Q61A0535	7	6	5	18	8	9	5	22	20

Avanthi Institute of Engineering and Technology

PRINCIPAL

Avanthi Institute of Engg. & Tech
Gunthapally (V), Abdullapurmet (M), R.R. Dist.



AVANTHI INSTITUTE OF ENGINEERING AND TECHNOLOGY

(Approved by AICTE, Recg. By Govt. of T.S & Affiliated to JNTUH, Hyderabad)

NAAC "B++" Accredited Institute

Gunthapally (V), Abdullapurmet(M), RR Dist, Near Ramoji Film City, Hyderabad -501512.

www.aietg.ac.in email: principal.avanthi@gmail.com

35	21Q61A0536	4	7	5	16	7	9	5	21	19
36	21Q61A0537	8	5	5	18	8	8	5	21	20
37	21Q61A0538	9	10	5	24	7	9	5	21	23
38	21Q61A0539	8	7	5	20	8	10	5	23	22
39	21Q61A0540	8	7	5	20	10	10	5	25	23
40	21Q61A0541	5	7	5	17	7	8	5	20	19
41	21Q61A0542	9	6	5	20	8	8	5	21	21
42	21Q61A0543	8	7	5	20	8	10	5	23	22
43	21Q61A0544	9	9	5	23	7	8	5	20	22
44	21Q61A0545	7	10	5	22	6	9	5	20	21
45	21Q61A0546	7	8	5	20	6	10	5	21	21
46	21Q61A0547	4	8	5	17	3	9	5	17	17
47	21Q61A0548	AB	AB	5	5	AB	AB	5	5	5
48	21Q61A0549	6	9	5	20	8	10	5	23	22
49	21Q61A0550	5	7	5	17	10	8	5	23	20
50	21Q61A0551	8	8	5	21	9	9	5	23	22
51	21Q61A0552	8	8	5	21	9	9	5	23	22
52	21Q61A0553	9	8	5	22	9	8	5	22	22
53	21Q61A0554	9	8	5	22	9	7	5	21	22
54	21Q61A0555	4	7	5	16	8	9	5	22	19
55	21Q61A0556	AB	AB	5	5	6	9	5	20	13
56	21Q61A0557	9	8	5	22	8	7	5	20	21
57	21Q61A0558	6	8	5	19	8	10	5	23	21
58	21Q61A0559	8	4	5	17	7	8	5	20	19
59	21Q61A0560	8	5	5	18	7	9	5	21	20

PRINCIPAL

PRINCIPAL
Avanthi Institute of Engg. & Tech
Gunthapally (V), Abdullapurmet (M), R.R. Dist.



AVANTHI INSTITUTE OF ENGINEERING AND TECHNOLOGY

(Approved by AICTE, Recg. By Govt. of T.S & Affiliated to JNTUH, Hyderabad)

NAAC "B++" Accredited Institute

Gunthapally (V), Abdullapurmet(M), RR Dist, Near Ramoji Film City, Hyderabad -501512.

www.aietg.ac.in email: principal.avanathi@gmail.com

III B. TECH II SEM (ACADEMIC YEAR 2022-23)-DISPLAY OF MARKS

BRANCH: MECH

S. NO	HT NO	C&D	DMM-II	FEM	HT	UCMP	FOM	HT LAB	C&D LAB	ACS LAB
1	20Q61A0301	15	23	23	23	23	23	24	21	21
2	20Q61A0302	14	21	22	21	20	20	17	22	22
3	20Q61A0303	18	23	23	23	23	23	24	21	21
4	20Q61A0304	5	5	5	5	5	5	5	5	5
5	21Q65A0301	5	5	5	5	5	5	5	5	5
7	21Q65A0302	18	23	23	23	23	23	18	23	23
8	21Q65A0303	24	25	24	23	23	23	25	23	23
9	21Q65A0304	24	25	25	25	23	23	25	23	23
11	21Q65A0306	5	5	5	25	5	5	5	5	5
12	21Q65A0307	21	23	22	23	23	23	18	23	23
13	21Q65A0308	24	25	25	23	23	23	24	21	21
14	21Q65A0309	19	24	24	25	20	20	19	23	23
15	21Q65A0310	16	20	21	24	19	19	16	22	22
16	21Q65A0311	18	21	22	20	21	21	17	21	21
17	21Q65A0312	15	22	23	21	21	21	19	21	21
18	21Q65A0313	5	5	5	5	5	5	5	5	5
19	21Q65A0314	22	25	25	22	23	23	25	22	22
20	21Q65A0315	20	23	23	23	23	23	23	23	23
21	21Q65A0316	21	24	24	24	22	22	24	23	23
22	21Q65A0317	18	19	19	19	23	23	16	21	21
23	21Q65A0318	19	19	20	19	21	21	18	21	21
24	21Q65A0319	20	19	20	19	21	21	16	21	21
25	21Q65A0321	18	22	22	22	21	21	19	22	22
26	21Q65A0322	16	19	20	19	21	20	16	22	24
27	21Q65A0323	19	20	21	20	20	20	17	21	21
28	21Q65A0324	24	25	25	25	23	23	20	21	21
29	21Q65A0325	19	19	20	19	17	17	18	22	22
30	21Q65A0326	19	19	20	19	19	19	16	21	21

PRINCIPAL

PRINCIPAL

Avanathi Institute of Engg. & Tech
Gunthapally (V), Abdullapurmet (M), R.R. Dist.



AVANTHI INSTITUTE OF ENGINEERING AND TECHNOLOGY

(Approved by AICTE, Regg. By Govt. of T.S & Affiliated to JNTUH, Hyderabad)

NAAC "B++" Accredited Institute

Gunthapally (V), Abdullapurmet(M), RR Dist, Near Ramoji Film City, Hyderabad -501512.

www.aietg.ac.in email: principal.avanthi@gmail.com

DEPARTMENT OF MECHANICAL ENGINEERING

MAJOR PROJECT DETAILS 2022-23

Batch No	Roll No	Name of the student	MAJOR PROJECT TITLE	GUIDE
1	19Q61A0308	J.SRINIVAS	COMPRESSED AIR CAR	Dr. Y.RAMESH BABU
	20Q65A0316	MARRU THARUN		
	19Q61A0302	KORNU VENKATESH		
	20Q65A0319	SABHAVAT SAINAIK		
2	20Q65A0303	MULE KEERTHANA	ROBOTIC ARM USING IOT	RV PRAHLAD
	20Q65A0312	JOGU RAJU		
	20Q65A0323	Y.VENU GOPALA KRISHNA		
3	19Q61A0306	MUNJAM SAIKIRAN	FULLY AUTOMATED SOLAR GRASS CUTTER	M. VEKATESHWARLU
	20Q65A0307	A.ANAND		
	20Q65A0321	SOMALA GOUTHAMI		
4	20Q65A0313	KANKURTHE NARESH	SHAFT DRIVEN BICYCLE	V. HARI NAYAK
	20Q65A0301	ADIKOPPULA ROHITH KUMAR		
	20Q65A0306	V PAVAN KUMAR		
5	19Q61A0307	PILLI VENKAT	AUTOMATIC HAMMER	Dr. G.RAMCHANDRA REDDY
	20Q65A0302	DOBBALA SANTHOSH KUMAR		
	19Q61A0305	L RAMBABU		
	20Q65A0304	SUPRIYA ENDOORI		
6	19Q61A0304	K ANIL KUMAR	2D CNC PLOTTER MACHINE	K SRIVENI
	19Q61A0309	P BHEEMARJUN REDDY		
	20Q65A0305	SUTHRALA VAMSHIKRISHNA		
7	19Q61A0303	KOTHUR THARUN	FABRICATION OF PAINTING ROBOT	A. SHANKAR
	20Q65A0311	JADHAV SOPAN		
	20Q65A0320	SAMPANGI SURYA KIRAN		
8	20Q65A0310	GORLA NAVEEN	FLOOR CLEANING ROBOT	K.SUMANTH
	20Q65A0314	K.NITISH KUMAR		
	20Q65A0317	PAGADALA SRILEKHA		
9	20Q65A0308	ANNAREDDY GANESH	SOLAR TRACKING ROBOT	B.SWATHI
	20Q65A0315	MATTA SAI KUMAR		
	20Q65A0318	RAMAVATH MATHRU		

PROJECT TEAM

GUIDE

HOD

PRINCIPAL

PRINCIPAL
Avanathi Institute of Engg. & Tech
Gunthapally (V), Abdullapurmet (M), R.R. Dist.



AVANTHI INSTITUTE OF ENGINEERING AND TECHNOLOGY

(Approved by AICTE, Recg. By Govt. of T.S & Affiliated to JNTUH, Hyderabad)

NAAC "B++" Accredited Institute

Gunthapally (V), Abdullapurmet(M), RR Dist, Near Ramoji Film City, Hyderabad -501512.

www.aietg.ac.in email: principal.avanthi@gmail.com

MAJOR PROJECT INTERNAL MARKS STATEMENT

IV B.TECH I SEMESTER REG R18

BATCH NO	ROLL NO	REV-1	REV-2	REV-3	REV-4	REV-5	RESULT
		(5m)	(5m)	(5m)	(5m)	(5m)	(25m)
1	19Q61A0308	5	4	5	5	4	23
	20Q65A0316	4	5	4	5	5	23
	19Q61A0302	5	4	5	4	4	22
	20Q65A0319	5	4	5	4	4	22
2	20Q65A0303	5	5	4	5	4	23
	20Q65A0312	4	4	5	4	5	22
	20Q65A0323	0	3	3	4	4	14
3	19Q61A0306	5	5	4	4	4	22
	20Q65A0307	4	4	4	4	5	21
	20Q65A0321	5	5	5	4	4	23
4	20Q65A0313	5	4	4	5	4	22
	20Q65A0301	4	5	5	4	5	23
	20Q65A0306	5	5	4	5	4	23
5	19Q61A0307	4	5	4	5	5	23
	20Q65A0302	5	5	5	4	4	23
	19Q61A0305	5	5	4	5	4	23
	20Q65A0304	4	4	5	5	4	22
6	19Q61A0304	5	5	5	4	4	23
	19Q61A0309	5	4	5	4	5	23
	20Q65A0305	5	5	4	4	4	22
7	19Q61A0303	4	4	5	5	5	23
	20Q65A0311	5	4	4	4	5	22
	20Q65A0320	4	4	5	5	5	23
8	20Q65A0310	5	4	5	4	4	22
	20Q65A0314	5	4	4	5	5	23
	20Q65A0317	5	5	5	4	4	23
9	20Q65A0308	4	4	4	5	5	22
	20Q65A0315	5	4	5	4	5	23
	20Q65A0318	5	5	4	5	4	23

PROJECT TEAM

GUIDE

HOD

PRINCIPAL

PRINCIPAL
Avanthi Institute of Engg. & Tech
Gunthapally (V), Abdullapurmet (M), R.R. Dist.



AVANTHI INSTITUTE OF ENGINEERING AND TECHNOLOGY

(Approved by AICTE, Regg. By Govt. of T.S & Affiliated to JNTUH, Hyderabad)

NAAC "B++" Accredited Institute

Gunthapally (V), Abdullapurmet(M), RR Dist, Near Ramoji Film City, Hyderabad -501512.

www.aietg.ac.in email: principal.avanthi@gmail.com

MAJOR PROJECT EXTERNAL MARKS STATEMENT

IV B.TECH I SEMESTER REG R18

BATCH NO	ROLL NO	REV-1	REV-2	REV-3	REV-4	REV-5	RESULT
		(15m)	(15m)	(15m)	(15m)	(15m)	(75m)
1	19Q61A0308	15	14	13	14	12	68
	20Q65A0316	10	11	12	14	14	65
	19Q61A0302	12	10	10	10	10	62
	20Q65A0319	10	10	10	10	10	60
2	20Q65A0303	14	15	14	15	14	72
	20Q65A0312	14	15	14	13	12	68
	20Q65A0323	12	12	14	15	15	68
3	19Q61A0306	12	12	13	13	15	65
	20Q65A0307	15	15	14	10	14	68
	20Q65A0321	12	14	14	15	15	70
4	20Q65A0313	14	15	14	14	15	72
	20Q65A0301	14	15	15	14	14	72
	20Q65A0306	10	12	13	15	15	65
5	19Q61A0307	14	15	14	14	15	72
	20Q65A0302	13	14	15	14	15	71
	19Q61A0305	14	14	13	14	15	70
	20Q65A0304	15	14	15	14	14	72
6	19Q61A0304	12	13	13	13	14	65
	19Q61A0309	14	13	12	14	15	68
	20Q65A0305	14	14	15	14	15	72
7	19Q61A0303	14	13	12	14	15	68
	20Q65A0311	14	14	15	15	14	72
	20Q65A0320	14	14	13	13	14	68
8	20Q65A0310	13	15	13	14	13	68
	20Q65A0314	14	14	12	14	14	68
	20Q65A0317	14	14	15	15	14	72
9	20Q65A0308	11	14	15	13	14	67
	20Q65A0315	13	13	14	14	14	68
	20Q65A0318	14	14	13	13	14	68

PROJECT TEAM

GUIDE

HOD

PRINCIPAL

PRINCIPAL
Avanthi Institute of Engg. & Tech
Gunthapally (V), Abdullapurmet (M), R.R. Dist.



SHAFT DRIVEN BICYCLE

A MAJOR PROJECT REPORT

Submitted in partial fulfillment of the requirements for the award of the

degree of

Bachelor of Technology in Mechanical Engineering

By

Mr. K. Naresh	(20Q65A0313)
Mr. V. Pavan Kumar	(20Q65A0306)
Mr. A. Rohith Kumar	(20Q65A0301)

Under the Guidance of

Mr. V. HARI NAYAK, istrad.

to the

DEPARTMENT OF MECHANICAL ENGINEERING
AVANTHI INSTITUTE OF ENGINEERING AND TECHNOLOGY
(Approved by AICTE, Recognized by Govt of T.S., & Affiliated to JNTU, Hyderabad)
(Accredited by NAAC with 'B++ Grade and NBA) Gunthapally (V),
Hayath Nagar (M), RR District, T.S. Pin: 501512.

2022 - 23

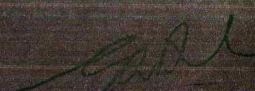
PRINCIPAL
Avanthi Institute of Engg. & Tech
Gunthapally (V), Abdulapurmet (MD), R.R. Dist.

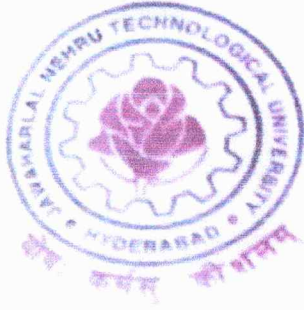

SHAFT DRIVEN BICYCLE

A MAJOR PROJECT REPORT

Submitted in partial fulfillment of the requirements for the award of the degree

Of

Bachelor of Technology in Mechanical Engineering

By

Mr. K. Naresh	(20Q65A0313)
Mr. V. Pavan Kumar	(20Q65A0306)
Mr. A. Rohith Kumar	(20Q65A0301)

Under the Guidance of

Mr. V. HARI NAYAK, M.Tech.

to the

DEPARTMENT OF MECHANICAL ENGINEERING,

AVANTHI INSTITUTE OF ENGINEERING AND TECHNOLOGY

(Approved by AICTE, Recognized by Govt of T.S., & Affiliated to JNTU, Hyderabad)

(Accredited by NAAC with 'B++ Grade and NBA)

Gunthapally (V), Hayath Nagar (M), RR District, T.S. Pin: 501512.

2022 - 23

PRINCIPAL

Avanthi Institute of Engg. & Tech
Gunthapally (V), Abdullapurmet (M), R.R. Dist.



AVANTHI INSTITUTE OF ENGINEERING AND TECHNOLOGY

(Approved by AICTE, Recognized by Govt of T.S., & Affiliated to J.N.T.U., Hyderabad)
Gunthapally (V), Hayath Nagar (M), R.R. District, T.S., India, Pin code - 501512
(Accredited by NAAC with 'B++' Grade and NBA)

Date:

DEPARTMENT OF MECHANICAL ENGINEERING CERTIFICATE

This is to certify that Major Project report titled "SHAFT DRIVEN BICYCLE" is a bonafide work of **Mr.K.Naresh**(20Q65A0313), and **Mr. Pavan Kumar**(20Q65A0306), and **Mr.A.Rohith Kumar**(20Q65A0301). They successfully completed this Major Project Work under the supervision of the internal guide in partial fulfillment of the requirements for the award of the **Bachelor of Technology in Mechanical Engineering** to the **Jawaharlal Nehru Technological University, Hyderabad** for the academic year 2022 -23. It is further Certified that the report submitted herein does not form part of any other Major Project or Project report or dissertation on the basis of which a Degree or Award was conferred on any earlier occasion on or any other candidate.

Hari Nayak
27/06/2023
Mr. HARI NAYAK
INTERNAL GUIDE

Dr. Y. Ramesh Babu
Dr. Y. RAMESH BABU
HEAD OF THE DEPARTMENT
Head of the Department
Mechanical Engineering
Avanthi Institute of Engineering & Technology
Gunthapally (V), Hayath Nagar (M), R.R. District, T.S., India, Pin code - 501512

G. Ramachandra Reddy
EXTERNAL EXAMINER

Dr. G. Ramachandra Reddy
Dr. G. RAMACHANDRA REDDY
PRINCIPAL

G. Ramachandra Reddy
PRINCIPAL
Avanthi Institute of Engg. & Tech.
Gunthapally (V), Abdullapurmet (Mdl), R.R. Dist.

PRINCIPAL
AVANTHI INSTITUTE OF
ENGINEERING & TECHNOLOGY
Gunthapally (V), Hayath Nagar (M),
R.R. Dist.



AVANTHI INSTITUTE OF ENGINEERING AND TECHNOLOGY

(Approved by AICTE, Regd. By Govt. of T.S & Affiliated to JNTUH, Hyderabad)

NAAC "B++" Accredited Institute

Gunthapally (V), Abdullapurmet(M), RR Dist, Near Ramoji Film City, Hyderabad -501512.

www.aietg.ac.in email: principal.avanathi@gmail.com

External lab Exam Circulars

Cir./Exam Section/0001

Date: 01-07-2023

Attention all the III B.TECH II SEM students are here by informing you that Lab External examinations will be conducted from 03-07-2023 to 08-07-2023.

Time: FN: 09.40 AM TO 11.00 AM

AN: 01.40 PM TO 03.00 PM

OIE

PRINCIPAL

PRINCIPAL
Avanathi Institute of Engg. & Tech
Gunthapally (V), Abdullapurmet (M), R.R. Dist.

Copy to: 1. ALL HOD's (EEE, MECH, ECE and CSE)

2. Administrative Office

3. Notice Boards

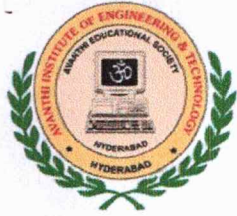

AVANTHI INSTITUTE OF ENGINEERING AND TECHNOLOGY

(Approved by AICTE, Regd. By Govt. of T.S & Affiliated to JNTUH, Hyderabad)

NAAC "B++" Accredited Institute

Gunthapally (V), Abdullapurmet(M), RR Dist, Near Ramoji Film City, Hyderabad -501512.

www.aietg.ac.in email: principal.avanthi@gmail.com

DEPARTMENT OF MECHANICAL ENGINEERING III B.TECH I SEM LAB EXTERNAL 2022-23

Branch	Lab Name	Internal Faculty Name	Phone Number	Date of External Exam	External Faculty Name	Phone Number	Mail Id
MECH	Kinematics & Dynamics Lab	Dr Y RAMESH BABU	9492492031	24-1-2023	Mr.M.Ashok	9491860866	ashoknewashok@gmail.com
	Metrology & Machine Tools Lab	Mr K SUMANTH	7337261267	26-1-2023	Mrs.M.Radhika	9440510372	mandalaradhika77@gmail.com
	Thermal Engineering Lab	Mr V HARI NAIK	9014502946	25-1-2023	Mr.P.Sadanandam	8885166065	sadasp11@gmail.com

HOD-ME

PRINCIPAL
Avanthi Institute of Engg. & Tech
Gunthapally (V), Abdullapurmet (Mdl), R.R. Dist.



AVANTHI INSTITUTE OF ENGINEERING AND TECHNOLOGY

(Approved by AICTE, Recg. By Govt. of T.S & Affiliated to JNTUH, Hyderabad)

NAAC "B++" Accredited Institute

Gunthapally (V), Abdullapurmet(M), RR Dist, Near Ramoji Film City, Hyderabad -501512.

www.aietg.ac.in email: principal.avanathi@gmail.com

III-II LAB EXTERNAL EXAMINATIONS – 2023

Subject: HT Lab

Exam: Lab External

Branch: Mechanical

Session: FN/AN

1. Step turning on lathe machine
2. Taper turning on lathe machine
3. Thread cutting and knurling on lathe machine (2 exercises)
4. Measurement of cutting forces on lathe
5. Machining of holes using drilling and boring machines.
6. Gear cutting on the milling machine
7. Grinding of tool angles using cylindrical / surface grinding
8. Measurement of lengths, heights, diameters by vernier calipers, micrometers.
9. Measurement of diameter of bores by internal micrometers and dial bore indicators.
10. Use of gear teeth vernier calipers for checking the chordal addendum and chordal height of the spur gear.
11. Angle and taper measurements by bevel protractor and sine bars.
12. Thread measurement by 2-wire and 3-wire methods.
13. Surface roughness measurement by tally surf.
14. Use of mechanical comparator

Internal Examiner Signature

External Examiner Signature

Signature of HOD

PRINCIPAL
Avanathi Institute of Engg. & Tech
Gunthapally (V), Abdullapurmet (M), R.R. Dist.

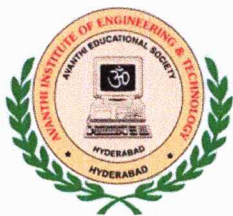

AVANTHI INSTITUTE OF ENGINEERING AND TECHNOLOGY

(Approved by AICTE, Recg. By Govt. of T.S & Affiliated to JNTUH, Hyderabad)

NAAC "B++" Accredited Institute

Gunthapally (V), Abdullapurmet(M), RR Dist, Near Ramoji Film City, Hyderabad -501512.

www.aietg.ac.in email: principal.avanthi@gmail.com

DEPARTMENT OF MECHANICAL ENGINEERING

Year-Sem: III-I

AY: 2022-23

External Lab Exam@AVIH

Time: 09:30AM to 03:50PM

Date	Branch	Forenoon		Afternoon		
		Year/Sem	Name of the Lab	Year-Sem/Sec	Name of the Lab	Name of the Internal Examiner
24-01-2023	MECH	III/I	Kinematics & Dynamics Lab	III/I	Kinematics & Dynamics Lab	Dr Y RAMESH BABU
26-01-2023	MECH	III/I	Metrology & Machine Tools lab	III/I	Metrology & Machine Tools lab	Mr. K SUMANTH
25-01-2023	MECH	III/I	Thermal Engineering Lab	III/I	Thermal Engineering Lab	Mr V HARI NAYAK

HOD

PRINCIPAL
Avanthi Institute of Engg. & Tech
Gunthapally (V), Abdullapurmet (M), R.R. Dist.



AVANTHI INSTITUTE OF ENGINEERING AND TECHNOLOGY

(Approved by AICTE, Recg. By Govt. of T.S & Affiliated to JNTUH, Hyderabad)

NAAC "B++" Accredited Institute

Gunthapally (V), Abdullapurmet(M), RR Dist, Near Ramoji Film City, Hyderabad -501512.

www.aietg.ac.in email: principal.avanathi@gmail.com

DEPARTMENT OF MECHANICAL ENGINEERING

III B.TECH II SEMESTER LAB EXTERNAL EXAMINATIONS REGARDS-R18 REGARDS

AY 2022-23

Scheme of Evaluation

S.NO	EVALUTION PROCESS	MARKS
1	External Lab Exam	40
2	Day Today Work	15
3	Record and Observation	10
4	Viva	10

HOD

PRINCIPAL
Avanathi Institute of Engg. & Tech
Gunthapally (V), Abdullapurmet (M), R.R. Dist.



Jawaharlal Nehru Technological University Hyderabad
Kukatpally, Hyderabad - 500 085, Telangana State, India.

EXAMINATION BRANCH
PRACTICAL EXAMINATION ANSWER BOOK

7

College Stamp



No.: 22621336

(8 pages)

PRINCIPAL'S FASCIMILE →

H.T.No.: 2 1 Q 6 5 A 0 3 2 1

K. Venkateswara Rao
Controller of Examinations

Name of the Examination 3rd B Tech 1st sem lab external Branch Mechanical

Lab Subject MMT Lab Date 24/01/2023

Signature of the Student with date 24/01/23

Signature of Internal Examiner with date 24/1/23

1. Candidates are prohibited from :

- i) Writing their Hall Ticket No. in any part of their Answer Books except in the space specially provided for the purpose.
- ii) Writing their names or symbols in any manner whatsoever in their Answer Books.
- iii) Addressing the examiner in any manner whatsoever in their Answer Books.

If they do so, their Answer Books will not be valued and the student will be booked under Malpractice case.

2. The candidates are not allowed into the Lab (where the Lab Exam is scheduled), after 30 minutes from the time of commencement of the examination.
3. The candidates are not allowed to leave the Lab (where the Lab Exam is scheduled), for first 1½ hours from the time of commencement of the examination.
4. The candidate should not forget to enter Hall Ticket Number. Otherwise their Answer Book will not be valued.
5. Before beginning to answer any question, the candidate should write the correct question number.
6. Answer should be written on both sides of the paper.
7. Please leave a margin of 2.5 cm on the left side of each page. Do not write anything in the margin except the question numbers.
8. No loose sheets of paper will be allowed in to the Lab where the Exam is scheduled and no paper must be detached from the Answer Book
9. All additional Answer Sheets and Graph Sheets, if used, should be attached before the last sheet of the main Answer Book and fastened securely.
10. Answer must be legibly written.
11. This Answer Book should be returned to one of the examiners before leaving the Lab.
12. The Candidate will be booked under malpractice for damaging / not returning the Answer Book after the examination.

For Examiners' Award only

Description	Marks
Design / Code	38
Execution	14
Output / Results	10
Viva - Exam	9
Total	71

Total Marks obtained	71
Maximum Marks	75

Signature of External Examiner with date 24/1/23

Signature of Internal Examiner with date 24/1/23

Principal
Kukatpally (V), Hyderabad

Aim : To perform internal key way on
Cast iron cylindrical block of diameter
50 mm and width 20 mm by using
Slotting machine.

Material Required :

- * Cylindrical block of diameter 50 mm and width 20 mm
- * Slotting machine cutting tool.
- * ~~Cast iron~~
- * steel rule

Procedure :

- * check all the connections of the slotting machine
- * The tool is fixed with the tool post so the moment is perpendicular to the table
- * The work piece is now set on the vice, so the tool is just above the workpiece.

To perform internal key way on
 Cast iron cylindrical blank of diameter
 50 mm and length 20 mm by using

~~Slotting machine~~

~~Material Required:~~

* Cylindrical blank of diameter 50 mm and

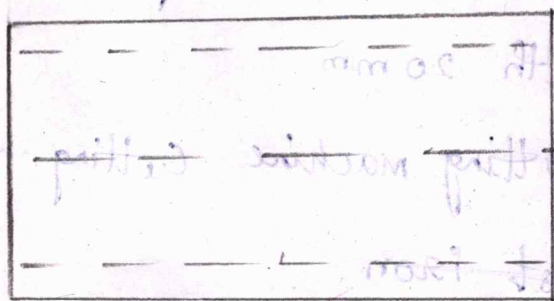
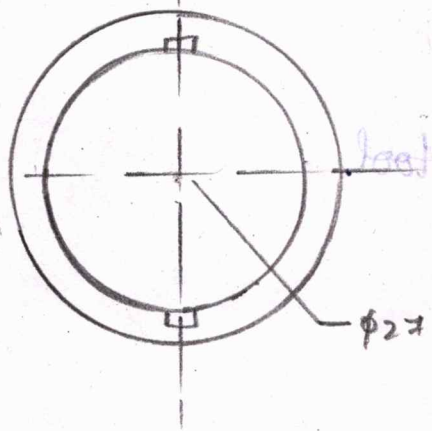

* Slotting machine cutting tool

* Cast iron

* Steel rule

Procedure:

* Check all the connections of the

~~slotting machine~~

* The tool is fixed with the table top so
 the movement is perpendicular to the

the work piece is now set on the
 table and the operator is

PRINCIPAL
 Avanthi Institute of Engg. & Tech
 Gunthapally (V), Abudullapurmet (M.D), R.R. Dist

10.10.20

work piece

- * Adjust the length of the stroke of the ram.
- * Slotting operation is performed now. make one slot on the workpiece. to the required 50 mm width and 20 mm diameter.
- * Then bring the tool to the initial position
- * Rotate the work table by required angle. Continue the process for the second slot
- * Repeat the process for the remaining slots.

Precautions :-

- * The work piece should be placed on vice securely and rigidly.
- * Never attempt to adjust the machine while it is in motion.
- * Suitable feeds and depths to cut should be maintain uniformly.

- * Always feed will be given to the backward stroke only.
- * Check the tool and tool holder to clear the work and also clear the column of the return stroke.

Result :-

The slotting is done on the given material of Cast iron cylindrical block of diameter 50 mm and width 20 mm by using slotting machine.

PRD



AVANTHI INSTITUTE OF ENGINEERING AND TECHNOLOGY

(Approved by AICTE, Recg. By Govt. of T.S & Affiliated to JNTUH, Hyderabad)

NAAC "B++" Accredited Institute

Gunthapally (V), Abdullapurmet(M), RR Dist, Near Ramoji Film City, Hyderabad -501512.

www.aietg.ac.in email: principal.avanthi@gmail.com

College Code: Q6

To
The Principal,
Vignan Institute of Technology and Science,
Deshmukhi(v),
Yadadri Bhuvanagiri.

Dear Sir,

Sub: Relieving Order - Lab External Examiner – Reg.

This is to certify that Mr/Mrs. M. ASHOK, Assistant Professor in Mech Department of Your institutions, has been completed successfully his/her duty as External Examiner for Kinematics & Dynamics Lab External Examination for B. Tech II Year I Semester for Mech Department at our college on 24/01/23.

He has been relieved from his duties in our college on 24/01/23, 4.00PM.

Thanking You Sir,

Yours faithfully,

PRINCIPAL

PRINCIPAL
Avanthi Institute of Engg. & Tech
Gunthapally (V), Abdullapurmet (Mdl), R.R. Dist.



AVANTHI INSTITUTE OF ENGINEERING AND TECHNOLOGY

(Approved by AICTE, Recg. By Govt. of T.S & Affiliated to JNTUH, Hyderabad)

NAAC "B++" Accredited Institute

Gunthapally (V), Abdullapurmet(M), RR Dist, Near Ramoji Film City, Hyderabad -501512.

www.aietg.ac.in email: principal.avanthi@gmail.com

College Code: Q6

To
The Principal,
Vignan Institute of Technology and Science,
Deshmukhi(v),
Yadadri Bhuvanagiri.

Dear Sir,

Sub: Relieving Order - Lab External Examiner – Reg.

This is to certify that Mr/Mrs. P. Sadanandam, Assistant Professor in Mech Department of Your institutions, has been completed successfully his/her duty as External Examiner for Thermal Engineering Lab External Examination for B. Tech III Year I Semester for Mech Department at our college on 25/01/23.

He has been relieved from his duties in our college on 25/01/23, 4.00PM.

Thanking You Sir,

Yours faithfully,

PRINCIPAL

PRINCIPAL
Avanathi Institute of Engg. & Tech
Gunthapally (V), Abdullapurmet (Mdl), R.R. Dist.



AVANTHI INSTITUTE OF ENGINEERING AND TECHNOLOGY

(Approved by AICTE, Recg. By Govt. of T.S & Affiliated to JNTUH, Hyderabad)

NAAC "B++" Accredited Institute

Gunthapally (V), Abdullapurmet(M), RR Dist, Near Ramoji Film City, Hyderabad -501512.

www.aietg.ac.in email: principal.avanathi@gmail.com

College Code: Q6

To
The Principal,
Vignan Institute of Technology and Science,
Deshmukhi(v),
Yadadri Bhuvanagiri.

Dear Sir,

Sub: Relieving Order - Lab External Examiner – Reg.

This is to certify that Mr/Mrs. M. Radhika, Assistant Professor in Mech Department of Your institutions, has been completed successfully his/her duty as External Examiner for Metrology & Machine Tools Lab External Examination for B. Tech III Year I Semester for Mech Department at our college on 26/01/23.

She has been relieved from her duties in our college on 26/01/23, 4.00PM.

Thanking You Sir,

Yours faithfully,

PRINCIPAL

PRINCIPAL
Avanathi Institute of Engg. & Tech
Gunthapally (V), Abdullapurmet (Mdl), R.R. Dist.

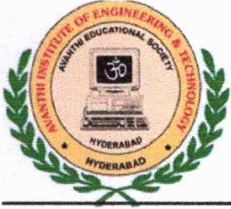

AVANTHI INSTITUTE OF ENGINEERING AND TECHNOLOGY

(Approved by AICTE, Regd. By Govt. of T.S & Affiliated to JNTUH, Hyderabad)

NAAC "B++" Accredited Institute

Gunthapally (V), Abdullapurmet(M), RR Dist, Near Ramoji Film City, Hyderabad -501512.

www.aietg.ac.in email: principal.avanthi@gmail.com

B.TECH, B.PHARMACY III YEAR II SEMESTER CBT UNIVERSITY EXAMS AUGUST- 2023

Allotted Observers from 08/08/2023 AND 09/08/2023 Date:05/08/2023

S.NO	OBSERVER_ID	OBSERVER_NAME	MOBILE_NO	COLLEGE CODE	COLLEGENAME	HOST CODE	HOSTNAME
1	GZIPP5911E	VYSHNAVI PITTALA	8519895715	1K	SREE CHAITANYA INSTITUTE OF PHARMACEUTICAL SCIENCES	S4	VAAGESWARI COLLEGE OF ENGINEERING
2	APPPM4658E	MANDA RAMESH	9346957396	TK	SVS GROUP OF INSTITUTIONS	UK	VAAGDEVI ENGINEERING COLLEGE
3	CMJPM3402M	MANDAVA HARSHA	8686811160	N7	DRK INSTITUTE OF SCIENCE & TECHNOLOGY	WH	BVRIT HYDERABAD COLLEGE OF ENGINEERING FOR WOMEN
4	BVNPk0794A	KYATHAM SUNEETHA	9849796878	FJ	SSJ COLLEGE OF PHARMACY	D2	SRIDEVI WOMEN'S ENGINEERING COLLEGE
5	AZIPK3463C	KASUBA VENKATA RAM MOHAN	9618439030	GE	BHASKAR ENGINEERING COLLEGE	J2	JOGINPALLY B.R. ENGINEERING COLLEGE
6	BDKPR8665Q	RELANGI VEDA PRAHLAD	9059199007	Q6	AVANTHI INSTITUTE OF ENGINEERING AND TECHNOLOGY	VE	SREYAS INSTITUTE OF ENGINEERING AND TECHNOLOGY
7	AZPPM8979A	MITTA CHAITANYA	9908977179	Z3	BOJJAM NARASIMHULU PHARMACY COLLEGE FOR WOMEN	E3	MAHAVEER INSTITUTE OF SCIENCE & TECHNOLOGY
8	OFQPS3427N	JINKALA VENKATA SIVA CHANDANA	7780687191	T2	CMR COLLEGE OF PHARMACY	UJ	MALLA REDDY ENGINEERING COLLEGE AND MANAGEMENT SCIENCES
9	DMRPP1139R	RAJ DIVYA POTH	8328363783	S7	HOLY MARY INSTITUTE OF TECHNOLOGY & SCIENCE (COLLEGE OF PHARMACY)	UP	VIGNAN'S INSTITUTE OF MANAGEMENT AND TECHNOLOGY FOR WOMEN
10	CDKPB9873P	BEEDHA SARASWATHI	9553226650	7M	MOTHER TERESA PHARMACY COLLEGE	C5	SAI SPURTHI INSTITUTE OF TECHNOLOGY

PRINCIPAL

PRINCIPAL

Avanathi Institute of Engg. & Tech
Gunthapally (V), Abdullapurmet (M), R.R. Dist.



Jawaharlal Nehru Technological University Hyderabad
Kukatpally, Hyderabad - 500 085, Telangana State, India.

EXAMINATION BRANCH
PRACTICAL EXAMINATION ANSWER BOOK

College Stamp

No.:

23791535

(8 pages)

PRINCIPAL'S FASCIMILE →

H.T.No.:

--	--	--	--	--	--	--	--	--	--

K. Venkateswara Rao

Controller of Examinations

Name of the Examination _____ Branch _____

Lab Subject _____ Date _____

Signature of the Student with date

Signature of Internal Examiner with date

1. Candidates are prohibited from :

- i) Writing their Hall Ticket No. in any part of their Answer Books except in the space specially provided for the purpose.
- ii) Writing their names or symbols in any manner whatsoever in their Answer Books.
- iii) Addressing the examiner in any manner whatsoever in their Answer Books.

If they do so, their Answer Books will not be valued and the student will be booked under Malpractice case.

2. The candidates are not allowed into the Lab (where the Lab Exam is scheduled), after 30 minutes from the time of commencement of the examination.
3. The candidates are not allowed to leave the Lab (where the Lab Exam is scheduled), for first 1½ hours from the time of commencement of the examination.
4. The candidate should not forget to enter Hall Ticket Number. Otherwise their Answer Book will not be valued.
5. Before beginning to answer any question, the candidate should write the correct question number.
6. Answer should be written on both sides of the paper.
7. Please leave a margin of 2.5 cm on the left side of each page. Do not write anything in the margin except the question numbers.
8. No loose sheets of paper will be allowed in to the Lab where the Exam is scheduled and no paper must be detached from the Answer Book
9. All additional Answer Sheets and Graph Sheets, if used, should be attached before the last sheet of the main Answer Book and fastened securely.
10. Answer must be legibly written.
11. This Answer Book should be returned to one of the examiners before leaving the Lab.
12. The Candidate will be booked under malpractice for damaging / not returning the Answer Book after the examination.

For Examiners' Award only

Description	Marks
Design / Code	
Execution	
Output / Results	
Viva - Exam	
Total	

Total Marks obtained

Maximum Marks

Signature of External Examiner with date

Signature of Internal Examiner with date

PRINCIPAL
Awards Institute of Engg. & Tech
Gunthapally (V), Abdullapurmet (Md), R.R. Dist.



Dr. K. VENKATESWARA RAO

M.Sc.,M.Tech.,PhD.,PDF(USA).

Professor of Nano Technology. &

DIRECTOR OF UNIVERSITY EXAMINATIONS

To,
The Principal,
AVANTHI INSTITUTE OF ENGINEERING AND TECHNOLOGY (Q6).

Dear Sir/Madam,

Sub:- Exam Branch-JNTUH-Appointment of Subject Experts from your college for Spot Valuation duty-Request for deputing the appointed subject experts-Reg.

I am glad to inform you that the following faculty members of your college have been appointed as subject experts for spot valuation duty at Examination Branch, JNTUH. You are requested to depute these faculty members duly adjusting the class work/Invigilation/other assignments and by issuing the relieving letter. The faculty members deputed for Spot valuation duty shall report at Examinations Building Spot Valuation Center-JNTUH Campus, Kukatpally, Hyderabad everyday by 10 AM. For any further clarifications please contact the reporting officer (mentioned in table here under).

Evaluator Name	Name of the Subject to be Evaluated	Dates of Valuation	Reporting Officer
MEKA SHIREESHA	DESIGN AND ANALYSIS OF ALGORITHMS	04-10-2023 to 07-10-2023	Additional Controllers of Examination 2
MALLIKANTI VENKATESWARLU	ENGINEERING MECHANICS	04-10-2023 to 07-10-2023	Additional Controllers of Examination 2
SWATHI ANNE	FLUID MECHANICS AND HYDRAULIC MACHINES	04-10-2023 to 07-10-2023	Additional Controllers of Examination 2
RAMESH BABU YELURI	MECHANICS OF FLUIDS AND HYDRAULIC MACHINES	04-10-2023 to 07-10-2023	Additional Controllers of Examination 2
ACHINI SHANKAR	THERMAL ENGINEERING I	04-10-2023 to 07-10-2023	Additional Controllers of Examination 2
RAGINI MALALI	NETWORK THEORY	04-10-2023 to 07-10-2023	Additional Controllers of Examination 2
MALOTH SHANKAR	NETWORK THEORY	04-10-2023 to 07-10-2023	Additional Controllers of Examination 2
SATISH KUMAR MATHALA	NETWORK ANALYSIS AND TRANSMISSION LINES	04-10-2023 to 07-10-2023	Additional Controllers of Examination 2
BANGARU SIDDHARTHA JETTY	NETWORK ANALYSIS AND TRANSMISSION LINES	04-10-2023 to 07-10-2023	Additional Controllers of Examination 2



PRINCIPAL
Avanthi Institute of Engg. & Tech

SHIVA SHANKER LAVUDYA	FORMAL LANGUAGES AND AUTOMATA THEORY	04-10-2023 to 07-10-2023	Additional Controllers of Examination 2
SHIVA SHANKER LAVUDYA	FORMAL LANGUAGE AND AUTOMATA THEORY	04-10-2023 to 07-10-2023	Additional Controllers of Examination 2
RAMANAREDDY NARU	TOTAL QUALITY MANAGEMENT	04-10-2023 to 07-10-2023	Additional Controllers of Examination 2
SUBHAN ALI SHAIK	FORMAL LANGUAGES AND AUTOMATA THEORY	04-10-2023 to 07-10-2023	Additional Controllers of Examination 2
MANDADI SURENDERREDDY	ENGINEERING MECHANICS	04-10-2023 to 07-10-2023	Additional Controllers of Examination 2
SEELAM SRIKANTH REDDY	NETWORK THEORY	04-10-2023 to 07-10-2023	Additional Controllers of Examination 2
ALLA SRAVANI	DATA STRUCTURES	04-10-2023 to 07-10-2023	Additional Controllers of Examination 2
SUBHAN ALI SHAIK	FORMAL LANGUAGE AND AUTOMATA THEORY	04-10-2023 to 07-10-2023	Additional Controllers of Examination 2

Please depute the faculty for spot valuation at examination branch, JNTUH. Each faculty of your college need to attend minimum 6 days. Your co-operation is highly solicited for the smooth conduct of spot valuation work.

sd/-

DIRECTOR OF UNIVERSITY EXAMINATIONS, JNTUH

PRINCIPAL
 Avanathi Institute of Engg. & Tech
 Cuntlapally (V), Abdullapurmet (M.C), R.R. Dist.

JAWAHARLAL NEHRU TECHNOLOGICAL UNIVERSITY HYDERABAD

HYDERABAD - 500 085, TELANGANA STATE, INDIA.

College: Q6 - AIET, HAYATHNAGAR



Sl. No. PC 05 50089



31678000140

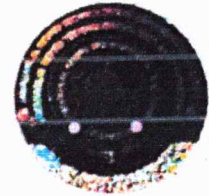

PROVISIONAL CERTIFICATE

21678000140

HT No: 20Q65A0305

This is to certify that Mr. SUTHRALA YAMSHIKRISHNA

S/o SUTHRALA GANGAMOHAN passed

B. Tech. ENGINEERING

degree examination of this University, held in July, 2023 and that

he was placed in FIRST CLASS.

He has satisfied all the requirements for the award of the degree.

Hyderabad - T.S.

Controller of Examinations

REGISTRAR

Date: August 21, 2023



PRINCIPAL
Avanathi Institute of Engg. & Tech
Gunthapally (V), Abdullapurmet (Mdl), R.R. Dist.

JAWAHARLAL NEHRU TECHNOLOGICAL UNIVERSITY HYDERABAD
HYDERABAD - 500 085, TELANGANA STATE, INDIA.



CONSOLIDATED MEMO OF MARKS/GRADES AND CREDITS

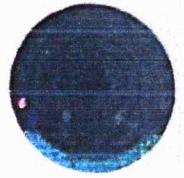

C5146097 B.Tech. MECHANICAL ENGINEERING



Name : SUTHRALA VAMSHIKRISHNA

Hall Ticket No : 20Q65A0305

Serial. No. : 21678000140

Year of Admission : 2020-2021

Name of the College : Q6-AIET,HAYATHNAGAR

Month & Year of Final Exam : July,2023

Class Awarded : FIRST CLASS

S.No.	SUBJECT TITLE	GRADE POINT	GRADE	CREDITS	S.No.	SUBJECT TITLE	GRADE POINT	GRADE	CREDITS
I SEMESTER					II SEMESTER				
I YEAR									
DIRECT ADMISSION INTO II-YEAR UNDER LATERAL ENTRY SCHEME									
I SEMESTER					II SEMESTER				
1	PRODUCTION TECHNOLOGY	5	C	3.0	1	BASIC ELECTRICAL AND ELECTRONICS ENGINEERING	5	C	3.0
2	PROBABILITY AND STATISTICS & COMPLEX VARIABLES	5	C	4.0	2	THERMAL ENGINEERING - I	5	C	4.0
3	MATERIAL SCIENCE AND METALLURGY	5	C	3.0	3	FLUID MECHANICS AND HYDRAULIC MACHINES	5	C	4.0
4	THERMODYNAMICS	6	B	4.0	4	INSTRUMENTATION AND CONTROL SYSTEMS	6	B	3.0
5	MECHANICS OF SOLIDS	7	B+	4.0	5	KINEMATICS OF MACHINERY	6	B	4.0
6	MACHINE DRAWING PRACTICE	10	O	1.0	6	FLUID MECHANICS AND HYDRAULIC MACHINES LAB	10	O	1.0
7	MATERIAL SCIENCE AND MECHANICS OF SOLIDS LAB	10	O	1.0	7	BASIC ELECTRICAL AND ELECTRONICS ENGINEERING LAB	10	O	1.0
8	PRODUCTION TECHNOLOGY LAB	10	O	1.0	8	INSTRUMENTATION AND CONTROL SYSTEMS LAB	10	O	1.0
9	CONSTITUTION OF INDIA ^	-	-	0.0	9	GENDER SENSITIZATION LAB ^	-	-	0.0
I SEMESTER					II SEMESTER				
1	DESIGN OF MACHINE MEMBERS - I	6	B	3.0	1	DESIGN OF MACHINE MEMBERS - II	6	B	3.0
2	BUSINESS ECONOMICS & FINANCIAL ANALYSIS	6	B	3.0	2	HEAT TRANSFER	5	C	4.0
3	METROLOGY & MACHINE TOOLS	7	B+	3.0	3	HEAT TRANSFER LAB	9	A+	1.0
4	THERMAL ENGINEERING - II	8	A	3.0	4	FUNDAMENTALS OF MANAGEMENT FOR ENGINEERS	5	C	3.0
5	DYNAMICS OF MACHINERY	5	C	4.0	5	FINITE ELEMENT METHODS	6	B	3.0
6	OPERATIONS RESEARCH	9	A+	3.0	6	CAD & CAM	7	B+	3.0
7	METROLOGY & MACHINE TOOLS LAB	10	O	1.0	7	CAD & CAM LAB	10	O	1.0
8	THERMAL ENGINEERING LAB	10	O	1.0	8	ADVANCED COMMUNICATION SKILLS LAB	10	O	1.0
9	KINEMATICS & DYNAMICS LAB	10	O	1.0	9	UNCONVENTIONAL MACHINING PROCESSES	9	A+	3.0
10	INTELLECTUAL PROPERTY RIGHTS ^	-	-	0.0	10	ENVIRONMENTAL SCIENCE ^	-	-	0.0
11	CYBER SECURITY ^	-	-	0.0	11	ARTIFICIAL INTELLIGENCE ^	-	-	0.0
I SEMESTER					II SEMESTER				
1	INDUSTRIAL ORIENTED MINI PROJECT / SUMMER INTERNSHIP	10	O	2.0	1	INDUSTRIAL MANAGEMENT	5	C	3.0
2	TURBO MACHINERY	6	B	3.0	2	INDUSTRIAL ROBOTICS	8	A	3.0
3	PRINCIPLES OF ENTREPRENEURSHIP	8	A	3.0	3	PROJECT STAGE - II	10	O	7.0
4	POWER PLANT ENGINEERING	8	A	3.0	4	TOTAL QUALITY MANAGEMENT	7	B+	3.0
5	PROJECT STAGE - I	10	O	3.0					
6	ADDITIVE MANUFACTURING	7	B+	3.0					
7	REFRIGERATION & AIR CONDITIONING	6	B	3.0					
8	SEMINAR	10	O	1.0					

Number of Credits registered and secured are **123**

Aggregate Marks/CGPA Secured : **6.99**

Date of Issue : **August-21-2023**

(see overleaf for rules pertaining to award of class)

PRINCIPAL
AV
Department of Engg. & Tech.
(^ Marks too low but passed) for award of class (see page 2)

CONTROLLER OF EXAMINATIONS

Year / Sem / Regulation / Branch Code / Sub. Code / Sub. Name
 II B.Tech I Sem Supplementary R18-05-153BK
 OBJECT ORIENTED PROGRAMMING USING C++
 Date : 05-10-2023(DAY 32)

2

Sl. No. : 2289517



YR CODE
2



PART - I

Course : B.Tech.
 Hall Ticket No. : 197Q1A05C0
 Name : MADA VIJENDER
 Examination : II B.Tech I Sem Supplementary R18
 Month-Year : Sep./Oct.-2023
 Branch : COMPUTER SCIENCE AND ENGINEERING(05)
 Subject Code : 153BK
 Subject Name : OBJECT ORIENTED PROGRAMMING USING C++
 Date of Exam : 05-10-2023(DAY 32)
 College Name : BGI(7Q)

MVA
 Signature of the Controller of exams

Signature of the Student with date

Signature of the Invigilator with date



DO NOT TEAR OFF THIS BARCODE

Control Bundle No.
3153BK

Do Not Write/Mark in Barcode area

This Part should be used by the Valuer during valuation of this Answer script
 Course : B.Tech. Branch : 05
 Subject Name : OBJECT ORIENTED PROGRAMMING USING C++
 Subject Code : 153BK
 Exam : II B.Tech I Sem Supplementary R18
 Month-Year : Sep./Oct.-2023
 Date of Exam : 05-10-2023(DAY 32)

MARKS AWARDED FOR QUESTIONS (for Examiner's award only)

JNTUH

Part - A								
Q.No	a	b	c	d	e	Total		
1								
	f	g	h	i	j			
Part - B								
Q.No	a	b	c	Q.No	a	b	c	Best Marks
2				3				
4				5				
6				7				
8				9				
10				11				
Grand Total								

Total Marks	Sl. No. of Answer Book in the Bundle
0	0
1	1
2	2
3	3
4	4
5	5
6	6
7	7
8	8
9	9

PART - II
 To be filled by the Student
 Subject Code as printed on top left corner of Question paper

Serial No of last page written

Control Bundle No. 3153BK

YR CODE

2

MARKS IN WORDS

First Digit	Second Digit

Signature of the Scrutinizer

Sl. No. of Ans. Book in Bundle

YR CODE
2

Course : B.Tech. Branch : 05
 Subject Name : OBJECT ORIENTED PROGRAMMING USING C++
 Subject Code : 153BK
 Exam : II B.Tech I Sem Supplementary R18
 Month-Year : Sep./Oct.-2023
 Date of Exam : 05-10-2023(DAY 32)

MARKS AWARDED FOR QUESTIONS (for Examiner's award only)

JNTUH

Part - A								
Q.No	a	b	c	d	e	Total		
1								
	f	g	h	i	j			
Part - B								
Q.No	a	b	c	Q.No	a	b	c	Best Marks
2				3				
4				5				
6				7				
8				9				
10				11				
Grand Total								

Total Marks	Sl. No. of Answer Book in the Bundle
0	0
1	1
2	2
3	3
4	4
5	5
6	6
7	7
8	8
9	9

PART - III
 To be filled by the Student
 Subject Code as printed on top left corner of Question paper

Serial No of last page written

Control Bundle No. 3153BK

YR CODE

2

MARKS IN WORDS

First Digit	Second Digit

Signature of the Scrutinizer

PRINCIPAL

Sl. No. of Ans. Book in Bundle

Bundle Number for Office use only
3153BK

Do Not Write/Mark in Barcode area



JAWAHARLAL NEHRU TECHNOLOGICAL UNIVERSITY HYDERABAD

KJUKATPALLY, HYDERABAD-500 085

PROCEEDINGS OF THE DIRECTOR OF EVALUATION

Procs.No.JNTUH/EB/B.Tech/VV/2023, Dt:9.1.2023

Sub: JNTUH - Examinaton Branch-Appointment of External Examiner for conduct of B.Tech Project Viva-Voce Exam -Orders-Issued.

ORDER

The Principal, Avanthi Inst. of Engg & Tech., has sent the panel of external examiners for conducting mini-project viva-voce examination for B.Tech. IV - I(R18 Regulation) Regular/supply and (R16 Regulation) project viva-voce supply students. They have requested the University to issue necessary orders for appointing the external examiners. The following is the list of examiners appointed to conduct the above mentioned project viva-voce examinations.

Name Of The Course	Approved External Examiner
B.Tech(EEE) Panel_Id : Q6_A_02_1_205	VENU MADHAV GOPALA Associate Professor EEE CVSR College of Engg venumadhav.gopala@gmail.com 9848749953
B.Tech(ME) Panel_Id : Q6_A_03_1_205	Dr. P. Prasanna Assistant Professor & Hostel Warden- Kinnera Hostel Mechanical JNTUHCEH prajntu@gmail.com 9885178361
B.Tech(ECE) (SECTION : 1) Panel_Id : Q6_A_04_1_205	ASHOK NALLAGONDA Assistant Professor ECE Kasireddy Narayan Reddy College of Engineering & Research ashokmtech2k8@gmail.com 9381188697
B.Tech(ECE) (SECTION : 2) Panel_Id : Q6_A_04_2_205	SREENIVASA AREMPULA Assistant Professor ECE Rishi M.S Institute of Engineering & Tech for women asraoecehod@gmail.com 9000598029

PRINCIPAL
Avanthi Institute of Engg. & Tech
KJUKATPALLY (M), Abdullapurmet (Md), R.R. Dist.

B.Tech(CSE) (SECTION : 1) Panel_Id : Q6_A_05_1_205	Dr. D. Vasumathi Professor&BoS Chairperson CSE JNTUHCEH vasukumar_devara@jntuh.ac.in 9989184685
B.Tech(CSE) (SECTION : 2) Panel_Id : Q6_A_05_2_205	NARESH KUNA Assistant Professor CSE T.K.R College of Engineering & Tech kuna48@gmail.com 9966362119
B.Tech(CSE) (SECTION : 3) Panel_Id : Q6_A_05_3_205	ERUKALA MAHENDER Assistant Professor CSE Geetanjali College of Engg & Tech mahee99@gmail.com 9912058007

The Principal is requested to arrange for conduct of Project viva-voce examination before the due date mentioned in the notification and upload the project viva-voce awarded marks to the JNTUH University Examination Registrations Portal on the same day. Take the printout of system generated marks report and get it signed with internal & external examiners and submit the same to DE/JNTUH.

TO
THE PRINCIPAL
Avanathi Inst. of Engg & Tech.

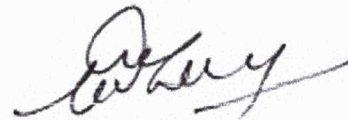

DIRECTOR OF EVALUATION



PRINCIPAL
Avanathi Institute of Engg. & Tech
Cunthapally (V), Abdullapurmet (M), R.R. Dist.



AVANTHI INSTITUTE OF ENGINEERING AND TECHNOLOGY

(Approved by AICTE, Recg. By Govt. of T.S & Affiliated to JNTUH, Hyderabad)

NAAC "B++" Accredited Institute

Gunthapally (V), Abdullapurmet(M), RR Dist, Near Ramoji Film City, Hyderabad -501512.

www.aietg.ac.in email: principal.avanthi@gmail.com

List of External Grievances

Any grievances related to End examinations are brought to the notice of the Examination cell. The cell sends a letter to the university immediately if necessary. The University takes immediate action based on the grievance. If a student is not satisfied with the marks allotted to his/her in the End examination, he/she can opt for Revaluation, Recounting or Challenge evaluation after paying the requisite fee to the university. If the students are opting for re-evaluation/rechecking of their answer scripts the same is submitted to the university to do the needful. Hence the mechanism adopted by the college is transparent, time bound and efficient. Grievances related to mistakes in certificates are handled by the Examination cell by taking up the matter to the university. The below given list is the number of students applied for the Revaluation /Recounting and number of students whose marks are changed for the academic year 2022-2023.

The total number of External Grievances: 168 (Students applied for Recounting / Revaluation is 87, Modification in Certificates etc,-16)

The number of students whose marks are changed is 10,

The number of Modification in Certificates are changed is 16

Percentage= $168/26= 6.461$

S. No	Academic Year	Semester	Total Applied/Change
1	2022-2023	I-I	7/2
2	2022-2023	I-II	35/01
3	2022-2023	II-II	45/07
4	2022-2023	Replacement external Examiner for project viva	01
5	2022-2023	Request for Transcripts	01
6	2022-2023	Observer Replacement	02
7	2022-2023	Missing Registrations	02
8	2022-2023	Hall Ticket Request	01
9	2022-2023	Decryption of paper	01
10	2022-2023	Subject Registration Mismatch	02
11	2022-2023	Request for late Registration	01
12	2022-2023	Gender correction	03
13	2022-2023	Photo Updation	01
14	2022-2023	Name Correction	11
15	2022-2023	Student & Father Name Correction	01
16	2022-2023	No Backlog Letter	02
17	2022-2023	Issue of PC&CMM Tatkal	23

Avanthi Institute of Engineering and Technology
Gunthapally (V), Abdullapurmet (Mdl), R.R. Dist.

[Handwritten Signature]
PRINCIPAL
Avanthi Institute of Engineering & Tech.
Gunthapally (V), Abdullapurmet (Mdl), R.R. Dist.



AVANTHI INSTITUTE OF ENGINEERING AND TECHNOLOGY

(Approved by AICTE, Regd. By Govt. of T.S & Affiliated to JNTUH, Hyderabad)

NAAC "B++" Accredited Institute

Gunthapally (V), Abdullapurmet(M), RR Dist, Near Ramoji Film City, Hyderabad -501512.

www.aietg.ac.in email: principal.avanathi@gmail.com

Revaluation/Recounting Results for I B.Tech I semester (R18) Examinations Nov-2023

HT NO	SUBNAME	SUBCODE	INTERNALS	EXTERNALS	GRADE STATUS	CREDITS
19Q61A0516	CHEMISTRY	151AF	19	11	No Change	---
20Q61A0568	MATHEMATICS - I	151AA	18	10	No Change	---
20Q61A0568	CHEMISTRY	151AF	19	28	C	4

Date: 05-12-2023

Controller of Examinations (UG)

Baby
EXAMINATION BRANCH
AVANTHI INSTITUTE OF
ENGINEERING & TECHNOLOGY
Gunthapally (V), Abdullapurmet (Mdl.), P.

Principal
PRINCIPAL



AVANTHI INSTITUTE OF ENGINEERING AND TECHNOLOGY

(Approved by AICTE, Recg. By Govt. of T.S & Affiliated to JNTUH, Hyderabad)

NAAC "B++" Accredited Institute

Gunthapally (V), Abdullapurmet(M), RR Dist, Near Ramoji Film City, Hyderabad -501512.

www.aietg.ac.in email: principal.avanthi@gmail.com

Revaluation/Recounting Results for I B.Tech I semester (R22) Examinations Dec-2023

HT NO	SUB NAME	SUB CODE	INTERNALS	EXTERNALS	GRADE STATUS	CREDITS
22Q61A0465	APPLIED PHYSICS	181AA	25	9	No Change	---
22Q61A0589	ENGINEERING CHEMISTRY	181AJ	23	9	No Change	---
22Q61A05C5	ENGINEERING CHEMISTRY	181AJ	27	26	B	4
22Q61A05C5	MATRICES AND CALCULUS	181AN	28	12	No Change	---

Date: 05-12-2023

Controller of Examinations (UG)

EXAMINATION BRANCH
AVANTHI INSTITUTE OF
ENGINEERING & TECHNOLOGY
Gunthapally (V), Abdullapurmet (M), R.R. Dist.

PRINCIPAL

Avanthi Institute of Engineering and Technology
Gunthapally (V), Abdullapurmet (M), R.R. Dist.



AVANTHI INSTITUTE OF ENGINEERING AND TECHNOLOGY

(Approved by AICTE, Regd. By Govt. of T.S & Affiliated to JNTUH, Hyderabad)

NAAC "B++" Accredited Institute

Gunthapally (V), Abdullapurmet(M), RR Dist, Near Ramoji Film City, Hyderabad -501512.

www.aietg.ac.in email: principal.avanathi@gmail.com

Revaluation/Recounting Results for I B.Tech II semester (R16) Examinations Dec-2023

HT NO	SUB NAME	SUBCODE	INTERNALS	EXTERNALS	GRADE STATUS	CREDITS
17Q61A0505	MATHEMATICS - II	132AB	23	9	No Change	---

Date: 05-12-2023

Controller of Examinations (UG)

EXAMINATION BRANCH
AVANTHI INSTITUTE OF
ENGINEERING & TECHNOLOGY
Gunthapally (V), Abdullapurmet (Mdl.), R.R. Dist

PRINCIPAL



AVANTHI INSTITUTE OF ENGINEERING AND TECHNOLOGY

(Approved by AICTE, Recg. By Govt. of T.S & Affiliated to JNTUH, Hyderabad)

NAAC "B++" Accredited Institute

Gunthapally (V), Abdullapurmet(M), RR Dist, Near Ramoji Film City, Hyderabad -501512.

www.aietg.ac.in email: principal.avanathi@gmail.com

Revaluation/Recounting Results for I B.Tech II semester (R18) Examinations Dec-2023

HT NO	SUB NAME	SUBCODE	INTERNALS	EXTERNALS	GRADE STATUS	CREDITS
19Q61A0447	MATHEMATICS - II	152AA	20	11	No Change	---
19Q61A05A7	MATHEMATICS - II	152AA	23	11	No Change	---
19Q61A05C9	MATHEMATICS - II	152AA	19	17	No Change	---
19Q61A05E4	MATHEMATICS - II	152AA	22	17	No Change	---
20Q61A0566	MATHEMATICS - II	152AA	23	14	No Change	---
20Q61A0568	MATHEMATICS - II	152AA	24	14	No Change	---
21Q61A6662	BASIC ELECTRICAL ENGINEERING	152AC	21	13	No Change	---
20Q61A0568	APPLIED PHYSICS	152AE	21	11	No Change	---
21Q61A6651	BASIC ELECTRICAL ENGINEERING	152AC	20	12	No Change	---
21Q61A6662	CHEMISTRY	152AB	19	16	No Change	---

Date: 05-12-2023

Controller of Examinations (UG)

EXAMINATION BRANCH
AVANTHI INSTITUTE OF
ENGINEERING & TECHNOLOGY
Gunthapally (V), Abdullapurmet (M), R.R. Dist

PRINCIPAL

Avanathi Institute of Engineering and Technology

Gunthapally (V), Abdullapurmet (M), R.R. Dist



AVANTHI INSTITUTE OF ENGINEERING AND TECHNOLOGY

(Approved by AICTE, Regd. By Govt. of T.S & Affiliated to JNTUH, Hyderabad)

NAAC "B++" Accredited Institute

Gunthapally (V), Abdullapurmet(M), RR Dist, Near Ramoji Film City, Hyderabad -501512.

www.aietg.ac.in email: principal.avanthi@gmail.com

Revaluation/Recounting Results for I B.Tech II semester (R22) Examinations Dec-2023

HT NO	SUB NAME	SUBCODE	INTER NALS	EXTER NALS	GRADE STATUS	CREDITS
22Q61A0416	ENGINEERING CHEMISTRY	182AH	28	9	No change	---
22Q61A0423	ENGINEERING CHEMISTRY	182AH	39	31	A	4
22Q61A0431	ENGINEERING CHEMISTRY	182AH	28	12	No change	----
22Q61A0442	ENGINEERING CHEMISTRY	182AH	32	2	No change	----
22Q61A0442	BASIC ELECTRICAL ENGINEERING	182AC	30	13	No change	----
22Q61A0442	ELECTRONIC DEVICES AND CIRCUITS	182AG	28	4	No change	----
22Q61A0562	ELECTRONIC DEVICES AND CIRCUITS	182AG	22	12	No change	----
22Q61A05C5	ELECTRONIC DEVICES AND CIRCUITS	182AG	24	11	No change	----
22Q61A0465	ELECTRONIC DEVICES AND CIRCUITS	182AG	33	13	No change	----
22Q61A05C6	ELECTRONIC DEVICES AND CIRCUITS	182AG	23	13	No change	----
22Q61A6706	ELECTRONIC DEVICES AND CIRCUITS	182AG	22	0	No change	----
22Q61A6723	ELECTRONIC DEVICES AND CIRCUITS	182AG	29	12	No change	----
22Q61A0442	ORDINARY DIFFERENTIAL EQUATIONS AND VECTOR CALCULUS	182AR	34	8	No change	----
22Q61A0508	ORDINARY DIFFERENTIAL EQUATIONS AND VECTOR CALCULUS	182AR	34	10	No change	----
22Q61A6723	ORDINARY DIFFERENTIAL EQUATIONS AND VECTOR CALCULUS	182AR	37	5	No change	----
22Q61A0442	COMPUTER AIDED ENGINEERING GRAPHICS	182AV	27	3	No change	----
22Q61A0508	APPLIED PHYSICS	182AB	26	11	No change	----
22Q61A05A5	APPLIED PHYSICS	182AB	15	15	No change	----
22Q61A05C6	APPLIED PHYSICS	182AB	25	12	No change	----
22Q61A6706	APPLIED PHYSICS	182AB	32	7	No change	----
22Q61A0562	ENGLISH FOR SKILL ENHANCEMENT	182AM	20	17	No change	----
22Q61A0589	ENGLISH FOR SKILL ENHANCEMENT	182AM	26	17	No change	----
22Q61A05A5	ENGLISH FOR SKILL ENHANCEMENT	182AM	15	18	No change	----
22Q61A6716	ENGLISH FOR SKILL ENHANCEMENT	182AM	26	14	No change	----

Date: 05-12-2023

Controller of Examinations (UG)

EXAMINATION BRANCH
AVANTHI INSTITUTE OF
ENGINEERING & TECHNOLOGY
Gunthapally (V), Abdullapurmet (M), R.R. Dist

PRINCIPAL
Avanthi Institute of Engineering and Technology
Gunthapally (V), Abdullapurmet (M), R.R. Dist.



AVANTHI INSTITUTE OF ENGINEERING AND TECHNOLOGY

(Approved by AICTE, Regd. By Govt. of T.S & Affiliated to JNTUH, Hyderabad)

NAAC "B++" Accredited Institute

Gunthapally (V), Abdullapurmet(M), RR Dist, Near Ramoji Film City, Hyderabad -501512.

www.aietg.ac.in email: principal.avanthi@gmail.com

Revaluation/Recounting Results for II B.Tech II semester (R18) Examinations Dec-2023

HT NO	SUB NAME	SUB CODE	INTERNALS	EXTERNALS	GRADE STATUS	CREDITS
21Q61A0211	DIGITAL ELECTRONICS	154AN	19	5	No change	---
21Q61A0211	ELECTRICAL MACHINES - II	154AU	22	12	No change	---
21Q61A0211	LAPLACE TRANSFORMS, NUMERICAL METHODS & COMPLEX VARIABLES	154BG	24	0	No change	---
21Q61A0211	POWER SYSTEM - I	154BW	21	12	No change	---
21Q61A0454	LAPLACE TRANSFORMS, NUMERICAL METHODS & COMPLEX VARIABLES	154BG	23	15	B	3
21Q61A0525	OPERATING SYSTEMS	154BR	19	16	No change	---
21Q61A0551	OPERATING SYSTEMS	154BR	21	14	No change	---
21Q61A0544	OPERATING SYSTEMS	154BR	22	29	No change	---
21Q61A0566	OPERATING SYSTEMS	154BR	19	14	No change	---
21Q61A0579	OPERATING SYSTEMS	154BR	20	19	No change	---
21Q61A0597	OPERATING SYSTEMS	154BR	15	19	No change	---
21Q61A6614	OPERATING SYSTEMS	154BR	20	20	No change	---
21Q61A0574	OPERATING SYSTEMS	154BR	21	19	No change	---
21Q61A0579	JAVA PROGRAMMING	154BE	24	17	No change	---
21Q61A0560	JAVA PROGRAMMING	154BE	20	17	No change	---
21Q61A0589	JAVA PROGRAMMING	154BE	22	9	No change	---
21Q61A0544	JAVA PROGRAMMING	154BE	21	15	No change	---
21Q61A0551	JAVA PROGRAMMING	154BE	21	26	C	4
21Q61A0593	JAVA PROGRAMMING	154BE	24	26	B	4
21Q61A0597	JAVA PROGRAMMING	154BE	20	14	No change	---
21Q61A0551	DATABASE MANAGEMENT SYSTEMS	154AM	21	8	No change	---
21Q61A0593	DATABASE MANAGEMENT SYSTEMS	154AM	21	16	No change	---
21Q61A6644	DATABASE MANAGEMENT SYSTEMS	154AM	25	0	No change	---
21Q61A6646	DATABASE MANAGEMENT SYSTEMS	154AM	24	0	No change	---
21Q61A6651	DATABASE MANAGEMENT SYSTEMS	154AM	22	25	No change	---
21Q61A6653	DATABASE MANAGEMENT SYSTEMS	154AM	23	7	No change	---
21Q61A0587	DATABASE MANAGEMENT SYSTEMS	154AM	20	16	No change	---
21Q61A0597	DATABASE MANAGEMENT SYSTEMS	154AM	17	26	C	4
21Q61A6615	DATABASE MANAGEMENT SYSTEMS	154AM	24	16	No change	---
21Q61A0558	BUSINESS ECONOMICS & FINANCIAL ANALYSIS	154AH	22	17	No change	---
21Q61A0566	BUSINESS ECONOMICS & FINANCIAL ANALYSIS	154AH	22	12	No change	---
21Q61A0572	BUSINESS ECONOMICS & FINANCIAL ANALYSIS	154AH	24	15	No change	---
21Q61A0587	BUSINESS ECONOMICS & FINANCIAL ANALYSIS	154AH	20	14	No change	---
21Q61A0589	BUSINESS ECONOMICS & FINANCIAL ANALYSIS	154AH	20	16	No change	---
21Q61A0597	BUSINESS ECONOMICS & FINANCIAL ANALYSIS	154AH	21	13	No change	---
21Q61A0572	DISCRETE MATHEMATICS	154AQ	21	15	No change	---
21Q61A6619	SOFTWARE ENGINEERING	154CQ	22	21	No change	---
21Q61A6651	SOFTWARE ENGINEERING	154CQ	22	20	No change	---
21Q61A6653	SOFTWARE ENGINEERING	154CQ	23	22	No change	---
21Q61A6707	FORMAL LANGUAGE AND AUTOMATA THEORY	154CK	24	0	No change	---
21Q61A6712	FORMAL LANGUAGE AND AUTOMATA THEORY	154CK	23	39	B+	3
21Q61A6739	FORMAL LANGUAGE AND AUTOMATA THEORY	154CK	25	30	B	3
21Q61A6744	FORMAL LANGUAGE AND AUTOMATA THEORY	154CK	25	28	B	3

EXAMINATION BRANCH
AVANTHI INSTITUTE OF
ENGINEERING & TECHNOLOGY
Gunthapally (V), Abdullapurmet (Mdl.), R.R. Dist

Avanthi Institute of Engineering and Technology

PRINCIPAL

Avanthi Institute of Engg. & Tech
Gunthapally (V), Abdullapurmet (Mdl.), R.R. Dist.



AVANTHI INSTITUTE OF ENGINEERING AND TECHNOLOGY

(Approved by AICTE, Regd. By Govt. of T.S & Affiliated to JNTUH, Hyderabad)

NAAC "B++" Accredited Institute

Gunthapally (V), Abdullapurmet(M), RR Dist, Near Ramoji Film City, Hyderabad -501512.

www.aietg.ac.in email: principal.avanthi@gmail.com

22Q65A0416	ELECTRONIC CIRCUIT ANALYSIS	154AW	22	14	No change	---
22Q65A0416	LINEAR IC APPLICATIONS	154BH	21	16	No change	---

Date: 05-12-2023

Controller of Examinations (UG)

EXAMINATION BRANCH
AVANTHI INSTITUTE OF
ENGINEERING & TECHNOLOGY
Gunthapally (V),
Abdullapurmet (M), R.R. Dist

PRINCIPAL
Avanthi Institute of Engineering and Technology

Avanthi Institute of Engg. & Tech
Gunthapally (V), Abdullapurmet (M), R.R. Dist.



in:sent



Compose

6 of 3,051

Inbox 11,066

Starred

Snoozed

Important

Sent

Drafts

Categories

Social 1

Updates 6,913

Forums 207

Promotions 1,649

More

Labels

[imap]/Sent

[imap]/Trash

AIET

Q6-Replacement of External Examiner for conduct of B.tech project viva voce exam- Request-Reg...



Avanthi Principal <principal.avanthi@gmail.com>
to support.registrations

Tue, Jun 27, 2023, 10:11AM

With respect to the subject cited above, Dr D Srinivasa Rao who is appointed as External Examiner of conduct B.tech IV-II ECE SECTION-1 viva voce exam is not willing to conduct due to his hectic schedule, so kindly replace external examiner with Dr N Ashok kumar, Associate Professor, KNR Inst of Eng & Tech.

I'm attaching order copy with your reference..

Dr.G.RAMACHANDRA REDDY

Principal

AVANTHI INSTITUTE OF ENGINEERING & TECHNOLOGY

Gunthapally(v),

Abdullapurmet(M).

R.R.Dist.

Ph:9704755509

One attachment • Scanned by Gmail

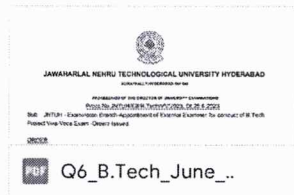

PRINCIPAL
Avanthi Institute of Engg. & Tech
Gunthapally (V), Abdullapurmet (M), R.R. Dist.



in:sent



Compose



5 of 3,051

Inbox

11,056

Starred

Snoozed

Important

Sent

Drafts

Categories

Social

1

Updates

6,913

Forums

207

Promotions

1,649

More

Labels

[imap]/Sent

[imap]/Trash

AJET

NANDU SRIKANTH REDDY TRANSCRIPTS



Avanathi Principal <principal.avanthi@gmail.com>
to intladmissions

Wed, Mar 29, 2023, 3:18 PM

Hai Good Afternoon...
please find below attachments
Dr.G.RAMACHANDRA REDDY
Principal
AVANTHI INSTITUTE OF ENGINEERING & TECHNOLOGY
Gunthapally(v),
Abdullapurmet(M).
R.R.Dist.
Ph:9704755509

One attachment • Scanned by Gmail



PDF NANDU SRIKANT...



Avanathi Principal <principal.avanthi@gmail.com>

3:14 PM (43 minutes ago)

PRINCIPAL
Avanthi Institute of Engg. & Tech
Gunthapally (V), Abdullapurmet (M), R.R. Dist.



in:sent



Compose



2 of 3,051

Inbox 11,056

Starred

Snoozed

Important

Sent

Drafts

Categories

Social 1

Updates 6,913

Forums 207

Promotions 1,649

More

Labels

[imap]/Sent

[imap]/Trash

AJET

Q6-OBSERVER REPLACEMENT-REQUEST-REG



Avanathi Principal <principal.avanathi@gmail.com>
to support.registrations

Fri, Jan 20, 2023, 11:33AM

Good Morning sir/madam

This is kindly brought to your notice Mrs **RAJPUROHIT SIRISHA** is suffering from viral fever so please replace observer with Mr **G Srinivas**, Assistant professor in the dept of ECE in our college.

Details of New Observer :

Name of the faculty : **G SRINIVAS**

PAN NUMBER : **BNMPG1488C**

MOBILE NUMBER : **9010214420**

MAIL ID : sri414china@gmail.com

Dr.G.RAMACHANDRA REDDY

Principal

AVANTHI INSTITUTE OF ENGINEERING & TECHNOLOGY

Gunthapally(v),

Abdullapurmet(M).

R.R.Dist.

Ph:9704755509



Avanathi Principal <principal.avanathi@gmail.com>
to a

3:18 PM (36 minutes ago)

PRINCIPAL
Avanathi Institute of Engg. & Tech.
Gunthapally (V), Abdullapurmet (M), R.R. Dist.



in:sent



Compose



1 of 3,051

Inbox

11,066

Starred

Snoozed

Important

Sent

Drafts

Categories

Social

1

Updates

6,913

Forums

207

Promotions

1,649

More

Labels

[imap]/Sent

[imap]/Trash

AJET

Request letter for Students Industrial Visit.



Avanathi Principal <principal.avanathi@gmail.com>

Tue, Nov 15, 2022, 12:01PM

to mlaxmidhar

Dear Mr.Laxmidhar Sir,

In continuation to our telephonic discussion for a visit by our Electrical & Electronics Engineering Students to your esteemed organisation ,we are here with mailing the necessary requisition letter for your kind perusal.

we hope to accord your valuable permission at the earliest and your convenience.

S.Venkataramana

Ref :Mr.A.Srinivasa Rao

Controls & Schematics ,

Himayat Nagar Office.

Dr.G.RAMACHANDRA REDDY

Principal

AVANTHI INSTITUTE OF ENGINEERING & TECHNOLOGY

Gunthapally(v),

Abdullapurmet(M).

R.R.Dist.

Ph:9704755509

One attachment • Scanned by Gmail



(Handwritten Signature)
PRINCIPAL
Avanathi Institute of Engg. & Tech
Cunthapally (V), Abdullapurmet (M), R.R. Dist.



in:sent



3 of 3,051

Compose

Inbox 11,056

Starred

Snoozed

Important

Sent

Drafts

Categories

Social 1

Updates 6,913

Forums 207

Promotions 1,649

More

Labels

[imap]/Sent

[imap]/Trash

AJET

Q6-3-2 Sem registrations missing the following students hall tickets not received: 19Q61A0403 inbox x



Avanthi Principal <principal.avanathi@gmail.com>
to support.registrations

Wed, Feb 1, 2023, 4:47 PM

Dear Sir/Madam

This is to bring to your kind notice that, at the time of Supply Re-Registration one of our student Registration is missing, so kindly consider our request and issue hall ticket. The details of student is as follows

Roll Number : 19Q61A0403 (3-2 Supply)

Student Name: A TEJA REDDY

Im attaching fee paid receipt please verify

Dr.G.RAMACHANDRA REDDY

Principal

AVANTHI INSTITUTE OF ENGINEERING & TECHNOLOGY

Gunthapally(v),

Abdullapurmet(M).

R.R.Dist.

Ph:9704755509

One attachment • Scanned by Gmail



Hide side panel

PRINCIPAL
Avanthi Institute of Engg. & Tech
Gunthapally (V), Abdullapurmet (M), R.R. Dist.

Q6-22Q61A0592 -NOT RECEIVING HALLTICKET-REQUEST -REG..



Avanathi Principal <principal.avanathi@gmail.com>

Sun, Sep 3, 2023, 6:34 PM

to support.registrations

Good Evening sir/madam

With respect to the subject cited above, we are not receiving 1-2 Regular hall ticket of a particular number (i.e 22Q61A0592) so kindly issue hall ticket.

Here I'm attaching copy view registrations of 1-2 Regular CSE branch & student fee paid receipt at college level.

thank you...

Dr.G.RAMACHANDRA REDDY

Principal

AVANTHI INSTITUTE OF ENGINEERING & TECHNOLOGY

Gunthapally(v),

Abdullapurmet(M).

R.R.Dist.

Ph:9704755509

PRINCIPAL
Avanathi Institute of Engg. & Tech
Gunthapally (V), Abdullapurmet (M), R.R. Dist.

Q6-3-2 Sem registrations missing the following students hall tickets not received: 19Q61A05B7



Avanathi Principal <principal.avanathi@gmail.com>
to support.registrations

Wed, Feb 1, 2023, 4:45 PM

Dear Sir/Madam

This is to bring to your kind notice that, at the time of Supply Re-Registration one of our student Registration is missing, so kindly consider our request and issue hall ticket. The details of student is as follows

Roll Number : 19Q61A0403 (3-2 Supply)

Student Name: A TEJA REDDY

Im attaching fee paid receipt please verify

Dr.G.RAMACHANDRA REDDY

Principal

AVANTHI INSTITUTE OF ENGINEERING & TECHNOLOGY

Gunthapally(v),

Abdullapurmet(M).

R.R.Dist.

Ph:9704755509

One attachment • Scanned by Gmail

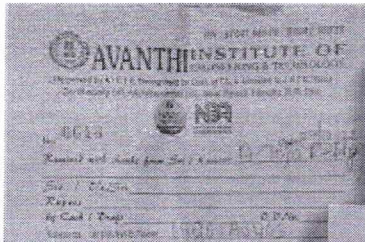

(Handwritten Signature)
PRINCIPAL
Avanathi Institute of Engg. & Tech
Gunthapally (V), Abdullapurmet (M), R.R. Dist.



in:sent



116 of 3,051

Compose

Inbox 11,086

Starred

Snoozed

Important

Sent

Drafts

Categories

Social 1

Updates 6,913

Forums 207

Promotions 1,449

More

Labels

[imap]/Sent

[imap]/Trash

AJET

Q6- PAPER NOT DECRYPTED-REQ-REG



Avanthi Principal <principal.avanthi@gmail.com>

Tue, Jul 25, 2023, 10:24 AM

to cejntuh

GOOD MORNING SIR/MADAM

Q6 COLLEGE - PAPER NOT DECRYPTED, PLEASE KINDLY RESOLVE ISSUE

Dr.G.RAMACHANDRA REDDY

Principal

AVANTHI INSTITUTE OF ENGINEERING & TECHNOLOGY

Gunthapally(v),

Abdullapurmet(M).

R.R.Dist.

Ph:9704755509

Reply

Forward



Handwritten signature

PRINCIPAL
Avanthi Institute of Engg. & Tech
Gunthapally (V), Abdullapurmet (M), R.R. Dist.



in:sent



134 of 3,051

Compose

Inbox 11,056

Starred

Snoozed

Important

Sent

Drafts

Categories

Social 1

Updates 6,913

Forums 207

Promotions 1,649

More

Labels

[imap]/Sent

[imap]/Trash

AIET

Q6 - Subject Registration mismatch

Inbox x



Avanthi Principal <principal.avanathi@gmail.com>

Tue, Jul 4, 2023, 6:07 PM

to support.registrations

Good Evening Sir/Madam,

With respect to subject cited above, for the roll number 20Q61A0539, we uploaded attendance to the Software testing methodologies lab, but we wrongly registered as Scripting language lab. So kindly update registration as Software testing methodologies lab instead of Scripting language lab.

Thank Q sir/madam.



support.registrations support.registrations <support.registrations@jntuh.ac.in>

Wed, Jul 5, 2023, 9:58 AM

to me

Keep the information on letterhead with the pr



support.registratio...

support.registrations@jntuh...



ion.

Thank you, I will do that.

Ok, I w

Open detailed view



PRINCIPAL
Avanthi Institute of Engg. & Tech
Cunthapally (V), Abdullapurmet (M.C), R.R. Dist.



in:sent



Compose



7 of 3,051

Q6 - Subject Registration mismatch-(20Q61A0539)

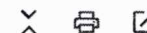

Inbox 11,056

Starred

Snoozed

Important

Sent

Drafts

Categories

Social 1

Updates 6,913

Forums 207

Promotions 1,649

More

Labels

[imap]/Sent

[imap]/Trash

AJET



Avanathi Principal <principal.avanathi@gmail.com>
to support.registrations

Wed, Jul 5, 2023, 10:36 AM

Good Morning sir/madam

With respect to the subject cited above, for the roll number 20Q61A0539, we uploaded attendance to the Software testing methodologies lab(15631), but we wrongly registered as a Scripting language lab(15629). So kindly update registration as Software testing methodologies lab(15631)instead of Scripting language lab(15629).

Please find below attachments

Dr.G.RAMACHANDRA REDDY

Principal

AVANTHI INSTITUTE OF ENGINEERING & TECHNOLOGY

Gunthapally(v),

Abdullapurmet(M).

R.R.Dist.

Ph:9704755509

2 Attachments • Scanned by Gmail

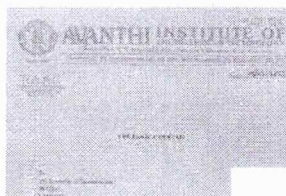
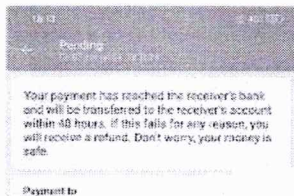

Handwritten signature in green ink
PRINCIPAL
Avanathi Institute of Engg. & Tech
Gunthapally (V), Abdullapurmet (M), R.R. Dist.



in:sent



8 of 3,051

Compose

Inbox 11,056

Starred

Snoozed

Important

Sent

Drafts

Categories

Social 1

Updates 6,913

Forums 207

Promotions 1,649

More

Labels

[imap]/Sent

[imap]/Trash

AIET

Q6 -REQUESTING FOR LATE REGISTRATION 20Q61A0583



Avanthi Principal <principal.avanathi@gmail.com>
to support.registrations

Sat, Jul 8, 2023, 4:59 PM

Dr.G.RAMACHANDRA REDDY

Principal

AVANTHI INSTITUTE OF ENGINEERING & TECHNOLOGY

Gunthapally(v),

Abdullapurmet(M),

R.R.Dist.

Ph:9704755509

SIR/MADAM REQUESTING FOR LATE REGISTRATION 20Q61A0583 PLEASE ISSUE THE HALTIKET

One attachment • Scanned by Gmail

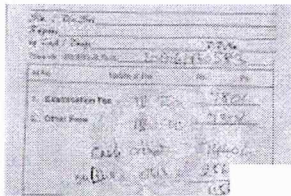

Avanthi Principal <principal.avanathi@gmail.com>

3:12 PM (47 minutes ago)

PRINCIPAL
Avanthi Institute of Engg. & Tech
Gunthapally (V), Abdullapurmet (M), R.R. Dist.



in:sent



Compose

114 of 3,051

Inbox 11,056

Starred

Snoozed

Important

Sent

Drafts

Categories

Social 1

Updates 6,913

Forums 207

Promotions 1,449

More

Labels

[imap]/Sent

[imap]/Trash

AJET



Avanthi Principal <principal.avanathi@gmail.com>

Mon, Jul 31, 2023, 4:45 PM

to ACE

DER: SIR/ MADEM Q6 AVANTHI INSTITUTE OF ENGINEERING AND TECHNOLOGY above students two members presents 18R35A0508;16R31A0585

Dr.G.RAMACHANDRA REDDY

Principal

AVANTHI INSTITUTE OF ENGINEERING & TECHNOLOGY

Gunthapally(v),

Abdullapurmet(M).

R.R.Dist.

Ph:9704755509

2 Attachments • Scanned by Gmail



Avanthi Principal <principal.avanathi@gmail.com>

Mon, Jul 31, 2023, 4:55 PM

to ACE

PRINCIPAL
Avanthi Institute of Engg. & Tech
Gunthapally (V), Abdullapurmet (M), R.R. Dist.



in:sent



Compose



107 of 3,051

FREE REGISTRATION-- National Training Programme on Blockchain Technology Hyperledger Development" from 21-25 August 2023 at ESCI , Hyd



Inbox x

Inbox

11,056

Starred

Snoozed

Important

Sent

Drafts

Categories

Social

1

Updates

6,913

Forums

207

Promotions

1,649

More



ENGINEERING STAFF COLLEGE OF INDIA

Sun, Aug 6, 2023, 1:56 PM

Dear Sir / Madam Greetings from ESCI !!! Engineering Staff College of India is Planning to Conduct the One Week Residential National Training program...



Avanathi Principal <principal.avanathi@gmail.com>

Mon, Aug 7, 2023, 9:22 AM

to aiet.csehod, avanthiece2005, kranthi, Mechanical

Dr.G.RAMACHANDRA REDDY

Principal

AVANTHI INSTITUTE OF ENGINEERING & TECHNOLOGY

Gunthapally(v),

Abdullapurmet(M).

R.R.Dist.

Ph:9704755509

Reply

Reply all

Forward



Labels

[imap]/Sent

[imap]/Trash

AJET

Handwritten signature
PRINCIPAL
Avanathi Institute of Engg. & Tech
Gunthapally (V), Abdullapurmet (M), R.R. Dist.



in:sent



11 of 3,051

Compose

Inbox 11,086

Starred

Snoozed

Important

Sent

Drafts

Categories

Social 1

Updates 6,913

Forums 207

Promotions 1,649

More

Labels

[imap]/Sent

[imap]/Trash

AIET

Q6-OBSERVER(CBT) REPLACEMENT-REQUEST-REG



Avanathi Principal <principal.avanthi@gmail.com>

Mon, Oct 30, 2023, 10:12AM

to support.registrations

Good Morning sir/madam

This is kindly brought to your notice Mr **ESLAVATH RAVI** is met with an accident, so please replace the observer with Mr **ACHINI SHANKAR**, Assistant professor in the dept of MECHANICAL in our college.

Details of New Observer :

Name of the faculty : **ACHINI SHANKAR**

PAN NUMBER : **BHIPA5509C**

MOBILE NUMBER : **8099246989**

MAIL ID : shankarshankar241@gmail.com

Dr.G.RAMACHANDRA REDDY

Principal

AVANTHI INSTITUTE OF ENGINEERING & TECHNOLOGY

Gunthapally(v),

Abdullapurmet(M).

R.R.Dist.

Ph:9704755509



Avanathi Principal <principal.avanthi@gmail.com>

3:06 PM (46 minutes ago)

to a

PRINCIPAL
Avanthi Institute of Engg. & Tech
Gunthapally (V), Abdullapurmet (M), R.R. Dist.



AVANTHI INSTITUTE OF ENGINEERING AND TECHNOLOGY

(Approved by AICTE, Recg. By Govt. of T.S & Affiliated to JNTUH, Hyderabad)

NAAC "B++" Accredited Institute

Gunthapally (V), Abdullapurmet(M), RR Dist, Near Ramoji Film City, Hyderabad -501512.

www.aietg.ac.in email: principal.avanthi@gmail.com

COLLEGE CODE: Q6

To

The Controller of Examinations,

JNTUH,

Kukatpally,

HYDERABAD-85.

SUB: Gender correction in B.Tech Hall Ticket & Profile –Request –Reg

Dear Sir,

With respect to the subject cited above name of **GADDAM SAHANA** bearing H.T.No 19Q61A0417, her gender was wrongly printed in Hall ticket as **MALE** instead of **FEMALE**.

It is requested to correct the gender as **FEMALE**,

Thanking you sir

Enclosure: 1) Payment Receipt

2) B.Tech hall ticket

3) SSC XEROX

Yours Sincerely,

PRINCIPAL





AVANTHI INSTITUTE OF ENGINEERING AND TECHNOLOGY

(Approved by AICTE, Recg. By Govt. of T.S & Affiliated to JNTUH, Hyderabad)

NAAC "B++" Accredited Institute

Gunthapally (V), Abdullapurmet(M), RR Dist, Near Ramoji Film City, Hyderabad -501512.

www.aietg.ac.in email: principal.avanathi@gmail.com

COLLEGE CODE: Q6

To

The Controller of Examinations,

JNTUH,

Kukatpally,

HYDERABAD-85.

SUB: Gender correction in B.Tech Hall Ticket & Profile –Request –Reg

Dear Sir,

With respect to the subject cited above name of **BANDI SINDHU** bearing H.T.No 19Q61A0409, her gender was wrongly printed in Hall ticket as **MALE** instead of **FEMALE**.

It is requested to correct the gender as **FEMALE**,

Thanking you sir

Enclosure: 1) Payment Receipt

2) B.Tech hall ticket

3) SSC XEROX

Yours Sincerely,

PRINCIPAL

PRINCIPAL
Avanathi Institute of Engg. & Tech
Gunthapally (V), Abdullapurmet (M), R.R. Dist.



AVANTHI INSTITUTE OF ENGINEERING AND TECHNOLOGY

(Approved by AICTE, Recg. By Govt. of T.S & Affiliated to JNTUH, Hyderabad)

NAAC "B++" Accredited Institute

Gunthapally (V), Abdullapurmet(M), RR Dist, Near Ramoji Film City, Hyderabad -501512.

www.aietg.ac.in email: principal.avanthi@gmail.com

COLLEGE CODE: Q6

To

The Controller of Examinations,

JNTUH,

Kukatpally,

HYDERABAD-85.

SUB: Gender correction in B.Tech Hall Ticket & Profile –Request –Reg

Dear Sir,

With respect to the subject cited above name of **PINNAPU REDDY MYTHLI REDDY** bearing H.T.No 19Q61A0441, her gender was wrongly printed in Hall ticket as **MALE** instead of **FEMALE**.

It is requested to correct the gender as **FEMALE**,

Thanking you sir

Enclosure: 1) Payment Receipt

2) B.Tech hall ticket

3) SSC XEROX

Yours Sincerely,

PRINCIPAL





AVANTHI INSTITUTE OF ENGINEERING AND TECHNOLOGY

(Approved by AICTE, Recg. By Govt. of T.S & Affiliated to JNTUH, Hyderabad)

NAAC "B++" Accredited Institute

Gunthapally (V), Abdullapurmet(M), RR Dist, Near Ramoji Film City, Hyderabad -501512.

www.aietg.ac.in email: principal.avanthi@gmail.com

COLLEGE CODE: Q6

To

The Controller of Examinations,

JNTUH,

Kukatpally,

HYD-85.

SUB: Photo updation in B.Tech Hall Ticket & Memos –Request –Reg

Dear Sir,

With respect to the subject cited above name of AITHAGONI VENKATESH bearing H.T.No 19Q61A0481, His photo was not printed in Hall ticket & memo's. Kindly update his photo in Hall ticket & memo's.

Thanking you sir

Enclosure: 1) soft copy of photo with CD

2) B.Tech hall ticket

yours faithfully,

PRINCIPAL

PRINCIPAL
Avanthi Institute of Engg. & Tech
Gunthapally (V), Abdullapurmet (Mdl), R.R. Dist.



AVANTHI INSTITUTE OF ENGINEERING AND TECHNOLOGY

(Approved by AICTE, Regd. By Govt. of T.S & Affiliated to JNTUH, Hyderabad)

NAAC "B++" Accredited Institute

Gunthapally (V), Abdullapurmet(M), RR Dist, Near Ramoji Film City, Hyderabad -501512.

www.aietg.ac.in email: principal.avanathi@gmail.com

COLLEGE CODE: Q6

To

The Controller of Examinations,

JNTUH,

Kukatpally,

HYDERABAD-85.

SUB: Name correction in B.Tech Hall Ticket & Memos –Request –Reg

Dear Sir,

With respect to the subject cited above name of JANGEELI PRAVEEN KUMAR PATEL bearing H.T.No 19Q61A0206, is wrongly printed in Hall ticket & memo's as JANGEELA PRAVEEN KUMAR instead of JANGEELI PRAVEEN KUMAR PATEL, S/O JANGEELI RAVI KUMAR.

It is requested to correct the name as JANGEELI PRAVEEN KUMAR PATEL,

S/O JANGEELI RAVI KUMAR.

Thanking you sir

Enclosure: 1) Payment Receipt

2) B.Tech hall ticket & 4 memos

3) SSC XEROX

yours faithfully,

PRINCIPAL

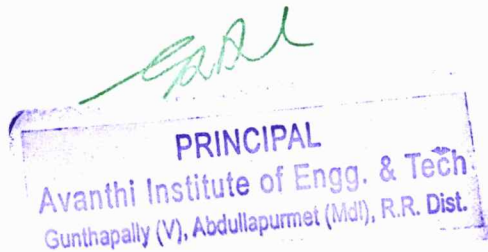



AVANTHI INSTITUTE OF ENGINEERING AND TECHNOLOGY

(Approved by AICTE, Recg. By Govt. of T.S & Affiliated to JNTUH, Hyderabad)

NAAC "B++" Accredited Institute

Gunthapally (V), Abdullapurmet(M), RR Dist, Near Ramoji Film City, Hyderabad -501512.

www.aietg.ac.in email: principal.avanthi@gmail.com

COLLEGE CODE: Q6

To

The Controller of Examinations,

JNTUH,

Kukatpally,

HYDERABAD-85.

SUB: Name correction in B.Tech Hall Ticket & Memos –Request –Reg

Dear Sir,

With respect to the subject cited above name of VILAPARTHI S R S G N P PANTHESWARA SARMA bearing H.T.No 20Q61A6709, is wrongly printed in Hall ticket & memo's as VILAPARTHI S R S G N P PANTHISWARA SARMA instead of VILAPARTHI S R S G N P PANTHESWARA SARMA, S/O VILAPARTHI SATISH.

It is requested to correct the name as VILAPARTHI S R S G N P PANTHESWARA SARMA,

S/O VILAPARTHI SATISH.

Thanking you sir

Enclosure: 1) Payment Receipt

2) B.Tech hall ticket & 1 memo

3) SSC XEROX

Yours faithfully,

PRINCIPAL

PRINCIPAL
Avanathi Institute of Engg. & Tech
Gunthapally (V), Abdullapurmet (Mdl), R.R. Dist.



AVANTHI INSTITUTE OF ENGINEERING AND TECHNOLOGY

(Approved by AICTE, Recg. By Govt. of T.S & Affiliated to JNTUH, Hyderabad)

NAAC "B++" Accredited Institute

Gunthapally (V), Abdullapurmet(M), RR Dist, Near Ramoji Film City, Hyderabad -501512.

www.aietg.ac.in email: principal.avanathi@gmail.com

COLLEGE CODE: Q6

To

The Controller of Examinations,

JNTUH,

Kukatpally,

HYDERABAD-85.

SUB: Name correction in B.Tech Hall Ticket & Memos –Request –Reg

Dear Sir,

With respect to the subject cited above name of THOTA NISHANTH bearing H.T.No 19Q61A05B9, is wrongly printed in Hall ticket & memo's as THOTA NISHATH instead of THOTA NISHANTH, S/O THOTA PRABHAKAR.

It is requested to correct the name as THOTA NISHANTH,

S/O THOTA PRABHAKAR.

Thanking you sir

Enclosure: 1) Payment Receipt

2) B.Tech hall ticket & 4 memos

3) SSC XEROX

Yours faithfully,

PRINCIPAL





AVANTHI INSTITUTE OF ENGINEERING AND TECHNOLOGY

(Approved by AICTE, Recg. By Govt. of T.S & Affiliated to JNTUH, Hyderabad)

NAAC "B++" Accredited Institute

Gunthapally (V), Abdullapurmet(M), RR Dist, Near Ramoji Film City, Hyderabad -501512.

www.aietg.ac.in email: principal.avanthi@gmail.com

COLLEGE CODE: Q6

To

The Controller of Examinations,

JNTUH,

Kukatpally,

HYDERABAD-85.

SUB: Name correction in B.Tech Marks Memos –Request –Reg

Dear Sir,

With respect to the subject cited above name of VANGALA SRINATH REDDY bearing H.T.No 19Q61A05E3, is wrongly printed in Marks memo's as VAGALA SRINATH REDDY instead of VANGALA SRINATH REDDY, S/O VANGALA RAVINDHAR REDDY.

It is requested to correct the name as VANGALA SRINATH REDDY,

S/O VANGALA RAVINDHAR REDDY.

Thanking you sir

Enclosure: 1) Demand Draft

2) B.Tech hall ticket & 2 memos

3) SSC XEROX

Yours faithfully,

PRINCIPAL



Avanthi Institute of Engineering and Technology



AVANTHI INSTITUTE OF ENGINEERING AND TECHNOLOGY

(Approved by AICTE, Recg. By Govt. of T.S & Affiliated to JNTUH, Hyderabad)

NAAC "B++" Accredited Institute

Gunthapally (V), Abdullapurmet(M), RR Dist, Near Ramoji Film City, Hyderabad -501512.

www.aietg.ac.in email: principal.avanathi@gmail.com

COLLEGE CODE: O6

To

The Controller of Examinations,

JNTUH,

Kukatpally,

HYDERABAD-85.

SUB: Name correction in B. Tech Hall Ticket & Memos –Request –Reg

Dear Sir,

With respect to the subject cited above name of **MATTA SAI KUMAR** bearing H.T.No 20Q65A0315, is wrongly printed in Hall ticket & Memos as **MATA SAI KUMAR** instead of **MATTA SAI KUMAR, S/O MATTA MALLESH.**

It is requested to correct the name as **MATTA SAI KUMAR,**

S/O MATTA MALLESH.

Thanking you sir

Enclosure: 1) Payment Receipt

2) B.Tech hall ticket

3) SSC XEROX

yours faithfully,

PRINCIPAL

PRINCIPAL
Avanathi Institute of Engg. & Tech
Gunthapally (V), Abdullapurmet (Mdl), R.R. Dist.



AVANTHI INSTITUTE OF ENGINEERING AND TECHNOLOGY

(Approved by AICTE, Recg. By Govt. of T.S & Affiliated to JNTUH, Hyderabad)

NAAC "B++" Accredited Institute

Gunthapally (V), Abdullapurmet(M), RR Dist, Near Ramoji Film City, Hyderabad -501512.

www.aietg.ac.in email: principal.avanthi@gmail.com

COLLEGE CODE: Q6

To

The Controller of Examinations,

JNTUH,

Kukatpally,

HYDERABAD-85.

SUB: Name correction in B.Tech Hall Ticket & Memos –Request –Reg

Dear Sir,

With respect to the subject cited above name of BUSI VASUDEV YADAV bearing H.T.No 19Q61A0549, is wrongly printed in Hall ticket & memos as BUSI VASU DEV YADAV instead of BUSI VASUDEV YADAV, S/O BUSI SRINIVAS YADAV.

It is requested to correct the name as BUSI VASUDEV YADAV,

S/O BUSI SRINIVAS YADAV.

Thanking you sir

Enclosure: 1) Payment Receipt

2) B.Tech hall ticket & 05 memos

3) SSC XEROX

Yours Sincerely,

PRINCIPAL

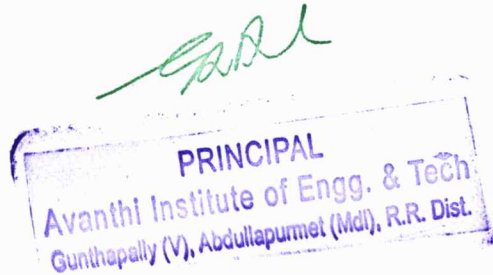



AVANTHI INSTITUTE OF ENGINEERING AND TECHNOLOGY

(Approved by AICTE, Recg. By Govt. of T.S & Affiliated to JNTUH, Hyderabad)

NAAC "B++" Accredited Institute

Gunthapally (V), Abdullapurmet(M), RR Dist, Near Ramoji Film City, Hyderabad -501512.

www.aietg.ac.in email: principal.avanthi@gmail.com

COLLEGE CODE: Q6

To

The Controller of Examinations,

JNTUH,

Kukatpally,

HYDERABAD-85.

SUB: Name correction in B.Tech Hall Ticket & Memos –Request –Reg

Dear Sir,

With respect to the subject cited above name of KOLA ESHWAR bearing H.T.No 19Q61A0207, is wrongly printed in Hall ticket & memos as KOLA ESWAR instead of KOLA ESHWAR, S/O KOLA KRISHNA.

It is requested to correct the name as KOLA ESHWAR,

S/O KOLA KRISHNA.

Thanking you sir

Enclosure: 1) Payment Receipt

2) B.Tech hall ticket & 08 memos

3) SSC XEROX

Yours Sincerely,

PRINCIPAL

PRINCIPAL
Avanthi Institute of Engg. & Tech
Gunthapally (V), Abdullapurmet (Mdl), R.R. Dist.

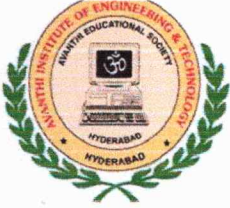

AVANTHI INSTITUTE OF ENGINEERING AND TECHNOLOGY

(Approved by AICTE, Recg. By Govt. of T.S & Affiliated to JNTUH, Hyderabad)

NAAC "B++" Accredited Institute

Gunthapally (V), Abdullapurmet(M), RR Dist, Near Ramoji Film City, Hyderabad -501512.

www.aietg.ac.in email: principal.avanthi@gmail.com

COLLEGE CODE: Q6

To

The Controller of Examinations,

JNTUH,

Kukatpally,

HYDERABAD-85.

SUB: Name correction in B.Tech Hall Ticket & Memos –Request –Reg

Dear Sir,

With respect to the subject cited above name of SRIPATHI ABHIRAM REDDY bearing H.T.No 19Q61A05D5, is wrongly printed in Hall ticket & memos as S ABHIMRAM REDDY instead of SRIPATHI ABHIRAM REDDY, S/O S SHEKHAR REDDY.

It is requested to correct the name as SRIPATHI ABHIRAM REDDY,

S/O S SHEKHAR REDDY.

Thanking you sir

Enclosure: 1) Payment Receipt

2) B.Tech hall ticket & 1 memo

3) SSC XEROX

Yours Sincerely,

PRINCIPAL

PRINCIPAL
Avanathi Institute of Engg. & Tech
Gunthapally (V), Abdullapurmet (Mdl), R.R. Dist.



AVANTHI INSTITUTE OF ENGINEERING AND TECHNOLOGY

(Approved by AICTE, Recg. By Govt. of T.S & Affiliated to JNTUH, Hyderabad)

NAAC "B++" Accredited Institute

Gunthapally (V), Abdullapurmet(M), RR Dist, Near Ramoji Film City, Hyderabad -501512.

www.aietg.ac.in email: principal.avanthi@gmail.com

COLLEGE CODE: Q6

To

The Controller of Examinations,

JNTUH,

Kukatpally,

HYDERABAD-85.

SUB: Name correction in B.Tech Hall Ticket & Memos –Request –Reg

Dear Sir,

With respect to the subject cited above name of BALUGURI PRASHANTH RAO bearing H.T.No 19Q61A0511, is wrongly printed in Hall ticket & memos as BALUGURI PRASANTH RAO instead of BALUGURI PRASHANTH RAO, S/O BALUGURI VENKAT RAO.

It is requested to correct the name as BALUGURI PRASHANTH RAO,

S/O BALUGURI VENKAT RAO.

Thanking you sir

Enclosure: 1) Payment Receipt

2) B.Tech hall ticket & 9 memo

3) SSC XEROX

Yours Sincerely,

PRINCIPAL

PRINCIPAL
Avanthi Institute of Engg. & Tech
Gunthapally (V), Abdullapurmet (Mdl), R.R. Dist.



AVANTHI INSTITUTE OF ENGINEERING AND TECHNOLOGY

(Approved by AICTE, Recg. By Govt. of T.S & Affiliated to JNTUH, Hyderabad)

NAAC "B++" Accredited Institute

Gunthapally (V), Abdullapurmet(M), RR Dist, Near Ramoji Film City, Hyderabad -501512.

www.aietg.ac.in email: principal.avanthi@gmail.com

COLLEGE CODE: Q6

To

The Controller of Examinations,

JNTUH,

Kukatpally,

HYDERABAD-85.

SUB: Student Name & Father Name correction in B.Tech Hall Ticket & Profile –Request –Reg

Dear Sir,

With respect to the subject cited above name of PINNAPUREDDY MYTHLI REDDY bearing H.T.No 19Q61A0441, is wrongly printed in Hall ticket as PINNIPUREDDY MYTHLI REDDY instead of PINNAPUREDDY MYTHLI REDDY, D/O PINNAPUREDDY JEIPAL REDDY.

It is requested to correct the name as PINNAPUREDDY MYTHLI REDDY,

D/O PINNAPUREDDY JEIPAL REDDY.

Thanking you sir

Enclosure: 1) Payment Receipt

2) B.Tech hall ticket & 11 memos

3) SSC XEROX

yours faithfully,

PRINCIPAL



JAWAHARLAL NEHRU TECHNOLOGICAL UNIVERSITY HYDERABAD

HYDERABAD - 500 085, TELANGANA STATE, INDIA.

College: **Q6 - AIET, HAYATHNAGAR**



Sl. No. PC 05 135 290



31672000911



PROVISIONAL CERTIFICATE

21672000901

HT No: **20Q65A0315**

This is to certify that Mr. **MATTA SAI KUMAR**

S/o **MATTA MALLESH** passed

B. Tech. **MECHANICAL ENGINEERING**

degree examination of this University, held in **July, 2023** and that

he was placed in **FIRST CLASS.**

He has satisfied all the requirements for the award of the degree.

Hyderabad - T.S.

Controller of Examinations

REGISTRAR

Date: July 27, 2023



PRINCIPAL

Avanathi Institute of Engg. & Tech
Gunthapally (V), Abdullapurmet (Mdl), R.R. Dist.



JAWAHARLAL NEHRU TECHNOLOGICAL UNIVERSITY HYDERABAD
HYDERABAD - 500 085, TELANGANA STATE, INDIA.



CONSOLIDATED MEMO OF MARKS GRADES AND CREDITS



C5138293 B.Tech. MECHANICAL ENGINEERING

Name : **MATTA SAI KUMAR**

Hall Ticket No : **20Q65A0315**

Serial. No. : 21672000901

Year of Admission : 2020-2021

Name of the College : Q6-AIET, HAYATHNAGAR

Month & Year of Final Exam : July, 2023

Class Awarded : **FIRST CLASS**

S.No	SUBJECT TITLE	GRADE POINT	GRADE	CREDITS	S.No	SUBJECT TITLE	GRADE POINT	GRADE	CREDITS
------	---------------	-------------	-------	---------	------	---------------	-------------	-------	---------

I SEMESTER

I YEAR

II SEMESTER

**DIRECT ADMISSION INTO II-YEAR UNDER
LATERAL ENTRY SCHEME**

I SEMESTER

II YEAR

II SEMESTER

1	PROBABILITY AND STATISTICS & COMPLEX VARIABLES	6	B	4.0	1	BASIC ELECTRICAL AND ELECTRONICS ENGINEERING	5	C	3.0
2	PRODUCTION TECHNOLOGY	5	C	3.0	2	KINEMATICS OF MACHINERY	5	C	4.0
3	MECHANICS OF SOLIDS	5	C	4.0	3	INSTRUMENTATION AND CONTROL SYSTEMS	6	B	3.0
4	MATERIAL SCIENCE AND METALLURGY	6	B	3.0	4	THERMAL ENGINEERING - I	6	B	4.0
5	THERMODYNAMICS	6	B	4.0	5	FLUID MECHANICS AND HYDRAULIC MACHINES	6	B	4.0
6	PRODUCTION TECHNOLOGY LAB	10	O	1.0	6	BASIC ELECTRICAL AND ELECTRONICS ENGINEERING LAB	10	O	1.0
7	MACHINE DRAWING PRACTICE	10	O	1.0	7	INSTRUMENTATION AND CONTROL SYSTEMS LAB	10	O	1.0
8	MATERIAL SCIENCE AND MECHANICS OF SOLIDS LAB	10	O	1.0	8	FLUID MECHANICS AND HYDRAULIC MACHINES LAB	10	O	1.0
9	CONSTITUTION OF INDIA ^	-	-	0.0	9	GENDER SENSITIZATION LAB ^	-	-	0.0

I SEMESTER

III YEAR

II SEMESTER

1	THERMAL ENGINEERING - II	5	C	3.0	1	HEAT TRANSFER	5	C	4.0
2	BUSINESS ECONOMICS & FINANCIAL ANALYSIS	5	C	3.0	2	HEAT TRANSFER LAB	7	B+	1.0
3	DESIGN OF MACHINE MEMBERS - I	5	C	3.0	3	ADVANCED COMMUNICATION SKILLS LAB	9	A+	1.0
4	METROLOGY & MACHINE TOOLS	6	B	3.0	4	DESIGN OF MACHINE MEMBERS - II	5	C	3.0
5	OPERATIONS RESEARCH	5	C	3.0	5	CAD & CAM	6	B	3.0
6	DYNAMICS OF MACHINERY	5	C	4.0	6	FINITE ELEMENT METHODS	5	C	3.0
7	THERMAL ENGINEERING LAB	9	A+	1.0	7	CAD & CAM LAB	9	A+	1.0
8	KINEMATICS & DYNAMICS LAB	9	A+	1.0	8	FUNDAMENTALS OF MANAGEMENT FOR ENGINEERS	6	B	3.0
9	METROLOGY & MACHINE TOOLS LAB	9	A+	1.0	9	UNCONVENTIONAL MACHINING PROCESSES	7	B+	3.0
10	INTELLECTUAL PROPERTY RIGHTS ^	-	-	0.0	10	ENVIRONMENTAL SCIENCE ^	-	-	0.0
11	CYBER SECURITY ^	-	-	0.0	11	ARTIFICIAL INTELLIGENCE ^	-	-	0.0

I SEMESTER

IV YEAR

II SEMESTER

1	INDUSTRIAL ORIENTED MINI PROJECT / SUMMER INTERNSHIP	9	A+	2.0	1	INDUSTRIAL MANAGEMENT	6	B	3.0
2	POWER PLANT ENGINEERING	7	B+	3.0	2	TOTAL QUALITY MANAGEMENT	7	B+	3.0
3	REFRIGERATION & AIR CONDITIONING	7	B+	3.0	3	INDUSTRIAL ROBOTICS	8	A	3.0
4	TURBO MACHINERY	5	C	3.0	4	PROJECT STAGE - II	10	O	7.0
5	PRINCIPLES OF ENTREPRENEURSHIP	7	B+	3.0					
6	ADDITIVE MANUFACTURING	8	A	3.0					
7	PROJECT STAGE - I	9	A+	3.0					
8	SEMINAR	9	A+	1.0					

Number of Credits registered and secured are: 123

Aggregate Marks/CGPA Secured : 6.57

Date of Issue : July 26, 2023

(see overleaf for rules concerned to award of class)

^ indicates 'ABSENT'



PRINCIPAL

CONTROLLER OF EXAMINATIONS

(* Mandatory course passed for award of degree)

(* Courses registered but not counted for calculation of aggregate)

Avanhi Institute of Engg. & Tech

Guwahati (Dr. Abdurazim (M)) P.P. Dist



AVANTHI INSTITUTE OF ENGINEERING AND TECHNOLOGY

(Approved by AICTE, Regg. By Govt. of T.S & Affiliated to JNTUH, Hyderabad)

NAAC "B++" Accredited Institute

Gunthapally (V), Abdullapurmet(M), RR Dist, Near Ramoji Film City, Hyderabad -501512.

www.aietg.ac.in email: principal.avanthi@gmail.com

NO BACKLOG LETTER

This is to certify that Mr./Ms. VISLAVATH PAVAN KUMAR S/o VISLAVATH RAMULU ; bearing Hall Ticket No 20Q65A0306 B. Tech (MECHANICAL ENGINEERING) Studied in Avanathi Institute of Engineering & Technology during 2020-2023 and completed all the courses without any backlogs and has met all the requirements for the award of B.Tech Degree.

His backlogs summary record is as follows.

Semester	Expected Passing year	Passing Year	No.of Re-appears	Re-appear Subjects
II year I semester	March 2021	April 2023	3	PROBABILITY AND STATISTICS & COMPLEX VARIABLES
	March 2021	Sep 2021	1	THERMO DYNAMICS
	March 2021	March 2022	2	MECHANICS OF SOLIDS
II year II semester	AUG 2021	AUG 2021	NILL	NILL
III year I semester	Feb 2022	Aug2022	1	THERMAL ENGINEERING-II
III year II semester	Aug2022	Feb 2023	1	Unconventional Machining Processes
	Aug2022	Feb 2023	1	Finite Element Methods
IV year I semester	JAN 2023	JULY 2023	1	REFRIGERATION AND AIR CONDITIONING
III year II semester	JULY 2023	JULY 2023	NILL	NILL

EXAM BRANCH

EXAMINATION BRANCH
AVANTHI INSTITUTE OF
ENGINEERING & TECHNOLOGY
Gunthapally (V), Abdullapurmet (M), R.R. Dist.

PRINCIPAL

PRINCIPAL
Avanathi Institute of Engg. & Tech
Gunthapally (V), Abdullapurmet (M), R.R. Dist.



AVANTHI INSTITUTE OF ENGINEERING AND TECHNOLOGY

(Approved by AICTE, Reg. By Govt. of T.S & Affiliated to JNTUH, Hyderabad)

NAAC "B++" Accredited Institute

Gunthapally (V), Abdullapurmet(M), RR Dist, Near Ramoji Film City, Hyderabad -501512.

www.aietg.ac.in email: principal.avanthi@gmail.com

NO BACKLOG LETTER

This is to certify that Mr./Ms. MOTAM NAVADEEP S/o MOTAM GANGAREDDY ; bearing Hall Ticket No 19Q61A0436 B. Tech (ELECTRONICS AND COMMUNICATION ENGINEERING) Studied in Avanthi Institute of Engineering & Technology during 2019-2023 and completed all the courses without any backlogs and has met all the requirements for the award of B.Tech Degree.

His backlogs summary record is as follows.

Semester	Expected Passing year	Passing Year	No.of Re-appears	Re-appear Subjects
I year I semester	Dec 2019	SEPT2021	3	Programming for problem solving
I year II semester	Nov 2020	July 2021	1	Basic electrical Engineering
	Nov 2020	June 2022	2	Chemistry
II year I semester	March 2021	Sept 2022	1	Network Analysis and Transmission lines
	March 2021	March 2022	2	Signals and Systems
II year II semester	AUG 2021	March 2022	1	Analog and Digital Communication
	AUG 2021	AUG 2022	2	Electromagnetic fields and Waves
	AUG 2021	March 2022	1	Laplace Transforms, Numerical Methods and Complex Variables
III year II semester	AUG 2022	Feb 2023	1	Digital Signal Processing
	AUG 2022	Feb 2023	1	VLSI Design



EXAM BRANCH

EXAMINATION BRANCH
AVANTHI INSTITUTE OF
ENGINEERING & TECHNOLOGY
Gunthapally (V), Abdullapurmet (Mdl.), R



PRINCIPAL

PRINCIPAL
Avanthi Institute of Engg. & Tech
Gunthapally (V), Abdullapurmet (Mdl.), R.R. Dist.



AVANTHI INSTITUTE OF ENGINEERING AND TECHNOLOGY

(Approved by AICTE, Regd. By Govt. of T.S & Affiliated to JNTUH, Hyderabad)

NAAC "B++" Accredited Institute

Gunthapally (V), Abdullapurmet(M), RR Dist, Near Ramoji Film City, Hyderabad -501512.

www.aietg.ac.in email: principal.avanthi@gmail.com

COLLEGE CODE: Q6

To,
The Director of Evaluation,
JNTUH, Kukatpally,
Hyderabad.



Sub: Issue of PC and CMM of MD ARFAZ bearing roll number 18Q65A0310, MECH branch by tatkal.

Dear Sir,

We have no objection for the university issuing the PC and CMM of MD ARFAZ bearing roll number 18Q65A0310, MECH branch under tatkal directly to the candidate. He has cleared all college dues.

Thanking You.

PRINCIPAL



PRINCIPAL
Avanthi Institute of Engg. & Tech
Gunthapally (V), Abdullapurmet (M), R.R. Dist.



AVANTHI INSTITUTE OF ENGINEERING AND TECHNOLOGY

(Approved by AICTE, Reg. By Govt. of T.S & Affiliated to JNTUH, Hyderabad)

NAAC "B++" Accredited Institute

Gunthapally (V), Abdullapurmet(M), RR Dist, Near Ramoji Film City, Hyderabad -501512.

www.aietg.ac.in email: principal.avanthi@gmail.com

COLLEGE CODE: Q6

To,
The Director of Evaluation,
JNTUH, Kukatpally,
Hyderabad.

Sub: Issue of PC and CMM of K SURESH bearing roll number 18D95A0304, MECH branch by tatkal.

Dear Sir,

We have no objection for the university issuing the PC and CMM of K SURESH bearing roll number 18D95A0304, MECH branch under tatkal directly to the candidate. He has cleared all college dues.

Thanking You.

PRINCIPAL

PRINCIPAL
Avanthi Institute of Engg. & Tech
Gunthapally (V), Abdullapurmet (M), R.R. Dist.



AVANTHI INSTITUTE OF ENGINEERING AND TECHNOLOGY

(Approved by AICTE, Reg. By Govt. of T.S & Affiliated to JNTUH, Hyderabad)

NAAC "B++" Accredited Institute

Gunthapally (V), Abdullapurmet(M), RR Dist, Near Ramoji Film City, Hyderabad -501512.

www.aietg.ac.in email: principal.avanthi@gmail.com

COLLEGE CODE: Q6

To,
The Director of Evaluation,
JNTUH, Kukatpally,
Hyderabad.

Sub: Issue of PC and CMM of **M NAGESHWAR RAO** bearing roll number
19Q61E0053, MBA branch by tatkal.

Dear Sir,

We have no objection for the university issuing the PC and CMM of
M NAGESHWAR RAO bearing roll number **19Q61E0053**, MBA branch under tatkal directly
to the candidate. He has cleared all college dues.

Thanking You.

PRINCIPAL

PRINCIPAL
Avanthi Institute of Engg. & Tech
Gunthapally (V), Abdullapurmet (Mdl), R.R. Dist.



AVANTHI INSTITUTE OF ENGINEERING AND TECHNOLOGY

(Approved by AICTE, Regg. By Govt. of T.S & Affiliated to JNTUH, Hyderabad)

NAAC "B++" Accredited Institute

Gunthapally (V), Abdullapurmet(M), RR Dist, Near Ramoji Film City, Hyderabad -501512.

www.aietg.ac.in email: principal.avanthi@gmail.com

COLLEGE CODE: Q6

To,
The Director of Evaluation,
JNTUH, Kukatpally,
Hyderabad.

Sub: Issue of PC and CMM of **PERUMALLA MANISAI** bearing roll number **18Q61A0432**, ECE branch by tatkal.

Dear Sir,

We have no objection for the university issuing the PC and CMM of **PERUMALLA MANISAI** bearing roll number **18Q61A0432**, ECE branch under tatkal directly to the candidate. He has cleared all college dues.

Thanking You.

PRINCIPAL

PRINCIPAL
Avanthi Institute of Engg. & Tech
Gunthapally (V), Abdullapurmet (Mdl), R.R. Dist.



AVANTHI INSTITUTE OF ENGINEERING AND TECHNOLOGY

(Approved by AICTE, Recg. By Govt. of T.S & Affiliated to JNTUH, Hyderabad)

NAAC "B++" Accredited Institute

Gunthapally (V), Abdullapurmet(M), RR Dist, Near Ramoji Film City, Hyderabad -501512.

www.aietg.ac.in email: principal.avanthi@gmail.com

COLLEGE CODE: Q6

To,
The Director of Evaluation,
JNTUH, Kukatpally,
Hyderabad.

Sub: Issue of PC and CMM of **MEKAPOTHALA SOUMYA** bearing roll number **18Q61A0581**, CSE branch by tatkal.

Dear Sir,

We have no objection for the university issuing the PC and CMM of **MEKAPOTHALA SOUMYA** bearing roll number **18Q61A0581**, CSE branch under tatkal directly to the candidate. She has cleared all college dues.

Thanking You.

PRINCIPAL



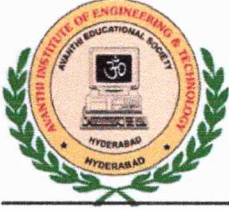

AVANTHI INSTITUTE OF ENGINEERING AND TECHNOLOGY

(Approved by AICTE, Recg. By Govt. of T.S & Affiliated to JNTUH, Hyderabad)

NAAC "B++" Accredited Institute

Gunthapally (V), Abdullapurmet(M), RR Dist, Near Ramoji Film City, Hyderabad -501512.

www.aietg.ac.in email: principal.avanathi@gmail.com

COLLEGE CODE: Q6

To,
The Director of Evaluation,
JNTUH, Kukatpally,
Hyderabad.

Sub: Issue of PC and CMM of **NALUMASU VAISHNAVI** bearing roll number **19Q65A0407**, ECE branch by tatkal.

Dear Sir,

We have no objection for the university issuing the PC and CMM of **NALUMASU VAISHNAVI** bearing roll number **19Q65A0407**, ECE branch under tatkal directly to the candidate. She has cleared all college dues.

Thanking You.

PRINCIPAL

PRINCIPAL
Avanthi Institute of Engg. & Tech
Gunthapally (V), Abdullapurmet (Mdl), R.R. Dist.



AVANTHI INSTITUTE OF ENGINEERING AND TECHNOLOGY

(Approved by AICTE, Reg. By Govt. of T.S & Affiliated to JNTUH, Hyderabad)

NAAC "B++" Accredited Institute

Gunthapally (V), Abdullapurmet(M), RR Dist, Near Ramoji Film City, Hyderabad -501512.

www.aietg.ac.in email: principal.avanthi@gmail.com

COLLEGE CODE: Q6

To,
The Director of Evaluation,
JNTUH, Kukatpally,
Hyderabad.

Sub: Issue of PC and CMM of **ERRI SAMAGNYA** bearing roll number
18Q61A0508, CSE branch by tatkal.

Dear Sir,

We have no objection for the university issuing the PC and CMM of

ERRI SAMAGNYA bearing roll number **18Q61A0508**, CSE branch under tatkal directly to the candidate. She has cleared all college dues.

Thanking You.

PRINCIPAL





AVANTHI INSTITUTE OF ENGINEERING AND TECHNOLOGY

(Approved by AICTE, Regd. By Govt. of T.S & Affiliated to JNTUH, Hyderabad)

NAAC "B++" Accredited Institute

Gunthapally (V), Abdullapurmet(M), RR Dist, Near Ramoji Film City, Hyderabad -501512.

www.aietg.ac.in email: principal.avanthi@gmail.com

COLLEGE CODE: Q6

To,
The Director of Evaluation,
JNTUH, Kukatpally,
Hyderabad.

Sub: Issue of PC and CMM of **K HARIKA** bearing roll number **19Q65A0427**, ECE branch by tatkal.

Dear Sir,

We have no objection for the university issuing the PC and CMM of **K HARIKA** bearing roll number **19Q65A0427**, ECE branch under tatkal directly to the candidate. She has cleared all college dues.

Thanking You.

PRINCIPAL

PRINCIPAL
Avanthi Institute of Engg. & Tech
Gunthapally (V), Abdullapurmet (Md), R.R. Dist.



AVANTHI INSTITUTE OF ENGINEERING AND TECHNOLOGY

(Approved by AICTE, Recg. By Govt. of T.S & Affiliated to JNTUH, Hyderabad)

NAAC "B++" Accredited Institute

Gunthapally (V), Abdullapurmet(M), RR Dist, Near Ramoji Film City, Hyderabad -501512.

www.aietg.ac.in email: principal.avanathi@gmail.com

COLLEGE CODE: Q6

To,
The Director of Evaluation,
JNTUH, Kukatpally,
Hyderabad.

Sub: Issue of PC and CMM of **KARANAM DIVYA BHANU** bearing roll number **18Q61A0458**, ECE branch by tatkal.

Dear Sir,

We have no objection for the university issuing the PC and CMM of

KARANAM DIVYA BHANU bearing roll number **18Q61A0458**, ECE branch under tatkal directly to the candidate. She has cleared all college dues.

Thanking You.

PRINCIPAL

PRINCIPAL
Avanthi Institute of Engg. & Tech
Gunthapally (V), Abdullapurmet (Mdl), R.R. Dist.



AVANTHI INSTITUTE OF ENGINEERING AND TECHNOLOGY

(Approved by AICTE, Reg. By Govt. of T.S & Affiliated to JNTUH, Hyderabad)

NAAC "B++" Accredited Institute

Gunthapally (V), Abdullapurmet(M), RR Dist, Near Ramoji Film City, Hyderabad -501512.

www.aietg.ac.in email: principal.avanathi@gmail.com

COLLEGE CODE: Q6

To,
The Director of Evaluation,
JNTUH, Kukatpally,
Hyderabad.

Sub: Issue of PC and CMM of **ALE AKHILA** bearing roll number **18Q61A0502**, CSE branch by tatkal.

Dear Sir,

We have no objection for the university issuing the PC and CMM of **ALE AKHILA** bearing roll number **18Q61A0502**, CSE branch under tatkal directly to the candidate. She has cleared all college dues.

Thanking You.

PRINCIPAL

PRINCIPAL
Avanathi Institute of Engg. & Tech
Gunthapally (V), Abdullapurmet (Mdl), R.R. Dist.



AVANTHI INSTITUTE OF ENGINEERING AND TECHNOLOGY

(Approved by AICTE, Regd. By Govt. of T.S & Affiliated to JNTUH, Hyderabad)

NAAC "B++" Accredited Institute

Gunthapally (V), Abdullapurmet(M), RR Dist, Near Ramoji Film City, Hyderabad -501512.

www.aietg.ac.in email: principal.avanthi@gmail.com

COLLEGE CODE: Q6

To,
The Director of Evaluation,
JNTUH, Kukatpally,
Hyderabad.

Sub: Issue of PC and CMM of **MUDIAM HARSHA VARDHAN REDDY** bearing roll number **18Q61A0583**, CSE branch by tatkal.

Dear Sir,

We have no objection for the university issuing the PC and CMM of **MUDIAM HARSHA VARDHAN REDDY** bearing roll number **18Q61A0583**, CSE branch under tatkal directly to the candidate. He has cleared all college dues.

Thanking You.

PRINCIPAL

PRINCIPAL
Avanathi Institute of Engg. & Tech
Gunthapally (V), Abdullapurmet (M), R.R. Dist.



AVANTHI INSTITUTE OF ENGINEERING AND TECHNOLOGY

(Approved by AICTE, Reg. By Govt. of T.S & Affiliated to JNTUH, Hyderabad)

NAAC "B++" Accredited Institute

Gunthapally (V), Abdullapurmet(M), RR Dist, Near Ramoji Film City, Hyderabad -501512.

www.aietg.ac.in email: principal.avanthi@gmail.com

COLLEGE CODE: Q6

To,
The Director of Evaluation,
JNTUH, Kukatpally,
Hyderabad.

Sub: Issue of PC and CMM of **GYARA AVINASH**, bearing roll number **19Q65A0306**, MECH branch by tatkal.

Dear Sir,

We have no objection for the university issuing the PC and CMM of **GYARA AVINASH** bearing roll number **19Q65A0306**, MECH branch under tatkal directly to the candidate. He has cleared all college dues.

Thanking You.

PRINCIPAL

PRINCIPAL
Avanthi Institute of Engg. & Tech
Gunthapally (V), Abdullapurmet (Mdl), R.R. Dist.



AVANTHI INSTITUTE OF ENGINEERING AND TECHNOLOGY

(Approved by AICTE, Reg. By Govt. of T.S & Affiliated to JNTUH, Hyderabad)

NAAC "B++" Accredited Institute

Gunthapally (V), Abdullapurmet(M), RR Dist, Near Ramoji Film City, Hyderabad -501512.

www.aietg.ac.in email: principal.avanathi@gmail.com

COLLEGE CODE: Q6

To,
The Director of Evaluation,
JNTUH, Kukatpally,
Hyderabad.

Sub: Issue of PC and CMM of **ETIKALA SAI CHARAN REDDY**, bearing roll number **18Q61A0411**, ECE branch by tatkal.

Dear Sir,

We have no objection for the university issuing the PC and CMM of

ETIKALA SAI CHARAN REDDY bearing roll number **18Q61A0411**, ECE branch under tatkal directly to the candidate. He has cleared all college dues.

Thanking You.

PRINCIPAL

PRINCIPAL
Avanathi Institute of Engg. & Tech
Gunthapally (V), Abdullapurmet (Mdl), R.R. Dist.



AVANTHI INSTITUTE OF ENGINEERING AND TECHNOLOGY

(Approved by AICTE, Recg. By Govt. of T.S & Affiliated to JNTUH, Hyderabad)

NAAC "B++" Accredited Institute

Gunthapally (V), Abdullapurmet(M), RR Dist, Near Ramoji Film City, Hyderabad -501512.

www.aietg.ac.in email: principal.avanathi@gmail.com

COLLEGE CODE: Q6

To,
The Director of Evaluation,
JNTUH, Kukatpally,
Hyderabad.

Sub: Issue of PC and CMM of **M RAMESH**, bearing roll number **18Q61A0421**, ECE branch by tatkal.

Dear Sir,

We have no objection for the university issuing the PC and CMM of

M RAMESH bearing roll number **18Q61A0421**, ECE branch under tatkal directly to the candidate. He has cleared all college dues.

Thanking You.

PRINCIPAL

PRINCIPAL
Avanathi Institute of Engg. & Tech
Gunthapally (V), Abdullapurmet (Mdl), R.R. Dist.



AVANTHI INSTITUTE OF ENGINEERING AND TECHNOLOGY

(Approved by AICTE, Recg. By Govt. of T.S & Affiliated to JNTUH, Hyderabad)

NAAC "B++" Accredited Institute

Gunthapally (V), Abdullapurmet(M), RR Dist, Near Ramoji Film City, Hyderabad -501512.

www.aietg.ac.in email: principal.avanthi@gmail.com

COLLEGE CODE: Q6

To,
The Director of Evaluation,
JNTUH, Kukatpally,
Hyderabad.

Sub: Issue of PC and CMM of **R VAMSHI KRISHNA**, bearing roll number **19Q65A0232**, EEE branch by tatkal.

Dear Sir,

We have no objection for the university issuing the PC and CMM of

R VAMSHI KRISHNA bearing roll number **19Q65A0232**, EEE branch under tatkal directly to the candidate. He has cleared all college dues.

Thanking You.

PRINCIPAL





AVANTHI INSTITUTE OF ENGINEERING AND TECHNOLOGY

(Approved by AICTE, Regg. By Govt. of T.S & Affiliated to JNTUH, Hyderabad)

NAAC "B++" Accredited Institute

Gunthapally (V), Abdullapurmet(M), RR Dist, Near Ramoji Film City, Hyderabad -501512.

www.aietg.ac.in email: principal.avanthi@gmail.com

COLLEGE CODE: Q6

To,
The Director of Evaluation,
JNTUH, Kukatpally,
Hyderabad.

Sub: Issue of PC and CMM of **BOYA MOHIT** bearing roll number **18Q61A0596**, CSE branch by tatkal.

Dear Sir,

We have no objection for the university issuing the PC and CMM of **BOYA MOHIT** bearing roll number **18Q61A0596**, CSE branch under tatkal directly to the candidate. He has cleared all college dues.

Thanking You.

PRINCIPAL

PRINCIPAL
Avanthi Institute of Engg. & Tech
Gunthapally (V), Abdullapurmet (Mdl), R.R. Dist.



AVANTHI INSTITUTE OF ENGINEERING AND TECHNOLOGY

(Approved by AICTE, Recg. By Govt. of T.S & Affiliated to JNTUH, Hyderabad)

NAAC "B++" Accredited Institute

Gunthapally (V), Abdullapurmet(M), RR Dist, Near Ramoji Film City, Hyderabad -501512.

www.aietg.ac.in email: principal.avanathi@gmail.com

COLLEGE CODE: Q6

To,
The Director of Evaluation,
JNTUH, Kukatpally,
Hyderabad.

Sub: Issue of PC and CMM of **MUSKU VAMSHI** bearing roll number
18Q61E0030, MBA branch by tatkal.

Dear Sir,

We have no objection for the university issuing the PC and CMM of
MUSKU VAMSHI bearing roll number **18Q61E0030**, MBA branch under tatkal directly to
the candidate. He has cleared all college dues.

Thanking You.

PRINCIPAL

PRINCIPAL
Avanathi Institute of Engg. & Tech
Gunthapally (V), Abdullapurmet (Mdl), R.R. Dist.



AVANTHI INSTITUTE OF ENGINEERING AND TECHNOLOGY

(Approved by AICTE, Recg. By Govt. of T.S & Affiliated to JNTUH, Hyderabad)

NAAC "B++" Accredited Institute

Gunthapally (V), Abdullapurmet(M), RR Dist, Near Ramoji Film City, Hyderabad -501512.

www.aictg.ac.in email: principal.avanthi@gmail.com

COLLEGE CODE: Q6

To,
The Director of Evaluation,
JNTUH, Kukatpally,
Hyderabad.

Sub: Issue of III-II Supply and IV-I Regular memo's of **PILLI SRI SAI RASHMITHA** bearing roll number **19Q61A05B0**, CSE branch by tatkal.

Dear Sir,

We have no objection for the university issuing III-II Supply and IV-I Regular memo's of **PILLI SRI SAI RASHMITHA** bearing roll number **19Q61A05B0**, CSE branch under tatkal directly to the candidate. She has cleared all college dues.

Thanking You.

PRINCIPAL

PRINCIPAL
Avanthi Institute of Engg. & Tech
Gunthapally (V), Abdullapurmet (Mdl), R.R. Dist.



AVANTHI INSTITUTE OF ENGINEERING AND TECHNOLOGY

(Approved by AICTE, Regg. By Govt. of T.S & Affiliated to JNTUH, Hyderabad)

NAAC "B++" Accredited Institute

Gunthapally (V), Abdullapurmet(M), RR Dist, Near Ramoji Film City, Hyderabad -501512.

www.aietg.ac.in email: principal.avanthi@gmail.com

COLLEGE CODE: Q6

To,
The Director of Evaluation,
JNTUH, Kukatpally,
Hyderabad.

Sub: Issue of PC and CMM of **K SRIKANTH** bearing roll number **19Q61A0463**, ECE branch by tatkal.

Dear Sir,

We have no objection for the university issuing the PC and CMM of **K SRIKANTH** bearing roll number **19Q61A0463**, ECE branch under tatkal directly to the candidate. He has cleared all college dues.

Thanking You.

PRINCIPAL

PRINCIPAL
Avanthi Institute of Engg. & Tech
Gunthapally (V), Abdullapurmet (Md), R.R. Dist.



AVANTHI INSTITUTE OF ENGINEERING AND TECHNOLOGY

(Approved by AICTE, Recg. By Govt. of T.S & Affiliated to JNTUH, Hyderabad)

NAAC "B++" Accredited Institute

Gunthapally (V), Abdullapurmet(M), RR Dist, Near Ramoji Film City, Hyderabad -501512.

www.aietg.ac.in email: principal.avanathi@gmail.com

COLLEGE CODE: Q6

To,
The Director of Evaluation,
JNTUH, Kukatpally,
Hyderabad.

Sub: Issue of PC and CMM of **PUNNA SAI MOUNIKA** bearing roll number **19Q61A0595**,
CSE branch by tatkal.

Dear Sir,

We have no objection for the university issuing the PC and CMM of
PUNNA SAI MOUNIKA bearing roll number **19Q61A0595**, CSE branch under tatkal directly
to the candidate. She has cleared all college dues.

Thanking You.

PRINCIPAL

PRINCIPAL
Avanathi Institute of Engg. & Tech
Gunthapally (V), Abdullapurmet (Mdl), R.R. Dist.



AVANTHI INSTITUTE OF ENGINEERING AND TECHNOLOGY

(Approved by AICTE, Regd. By Govt. of T.S & Affiliated to JNTUH, Hyderabad)

NAAC "B++" Accredited Institute

Gunthapally (V), Abdullapurmet(M), RR Dist, Near Ramoji Film City, Hyderabad -501512.

www.aietg.ac.in email: principal.avanathi@gmail.com

COLLEGE CODE: Q6

To,
The Director of Evaluation,
JNTUH, Kukatpally,
Hyderabad.

Sub: Issue of PC and CMM of **NUKAM REDDY SUNEELA** bearing roll number **19Q61A0594**, CSE branch by tatkal.

Dear Sir,

We have no objection for the university issuing the PC and CMM of **NUKAM REDDY SUNEELA** bearing roll number **19Q61A0594**, CSE branch under tatkal directly to the candidate. She has cleared all college dues.

Thanking You.

PRINCIPAL



PRINCIPAL
Avanathi Institute of Engg. & Tech
Gunthapally (V), Abdullapurmet (Mdl), R.R. Dist.



AVANTHI INSTITUTE OF ENGINEERING AND TECHNOLOGY

(Approved by AICTE, Reg. By Govt. of T.S & Affiliated to JNTUH, Hyderabad)

NAAC "B++" Accredited Institute

Gunthapally (V), Abdullapurmet(M), RR Dist, Near Ramoji Film City, Hyderabad -501512.

www.aietg.ac.in email: principal.avanthi@gmail.com

COLLEGE CODE: Q6

To,
The Director of Evaluation,
JNTUH, Kukatpally,
Hyderabad.

Sub: Issue of PC and CMM of **SALLA SAIKIRAN REDDY** bearing roll number **19Q61A05B6**, CSE branch by tatkal.

Dear Sir,

We have no objection for the university issuing the PC and CMM of **SALLA SAIKIRAN REDDY** bearing roll number **19Q61A05B6**, CSE branch under tatkal directly to the candidate. He has cleared all college dues.

Thanking You.

PRINCIPAL



PRINCIPAL
Avanthi Institute of Engg. & Tech
Gunthapally (V), Abdullapurmet (Mdl), R.R. Dist.



AVANTHI INSTITUTE OF ENGINEERING AND TECHNOLOGY

(Approved by AICTE, Regg. By Govt. of T.S & Affiliated to JNTUH, Hyderabad)

NAAC "B++" Accredited Institute

Gunthapally (V), Abdullapurmet(M), RR Dist, Near Ramoji Film City, Hyderabad -501512.

www.aietg.ac.in email: principal.avanthi@gmail.com

COLLEGE CODE: Q6

To,
The Director of Evaluation,
JNTUH, Kukatpally,
Hyderabad.

Sub: Issue of PC and CMM of **GUDURI PRASHANTH KUMAR** bearing roll number **19Q61A0461**, ECE branch by tatkal.

Dear Sir,

We have no objection for the university issuing the PC and CMM of **GUDURI PRASHANTH KUMAR** bearing roll number **19Q61A0461**, ECE branch under tatkal directly to the candidate. He has cleared all college dues.

Thanking You.

PRINCIPAL

PRINCIPAL
Avanthi Institute of Engg. & Tech
Gunthapally (V), Abdullapurmet (Mdl), R.R. Dist.



AVANTHI INSTITUTE OF ENGINEERING AND TECHNOLOGY

(Approved by AICTE, Regd. By Govt. of T.S & Affiliated to JNTUH, Hyderabad)

NAAC "B++" Accredited Institute

Gunthapally (V), Abdullapurmet(M), RR Dist, Near Ramoji Film City, Hyderabad -501512.

www.aietg.ac.in email: principal.avanthi@gmail.com

List of Internal Grievances

S. No	Academic Year	Nature of Issue/Grievance	Date of Issue Raised	Date of Issue solved
1	2022-23	Seeking Permission for Transport	18-11-2022	18-11-2022
2	2022-23	Seeking Permission for Transport	25-11-2022	25-11-22
3	2022-23	Seeking permission for Exam	23-07-2022	23-07-2022
4	2022-23	Seeking permission for Exam	14-05-2022	14-05-2022
5	2022-23	Seeking permission for Exam	10-03-2023	10-03-2023
6	2022-23	Seeking permission for Exam	15-03-2023	15-03-2023
7	2022-23	Seeking permission for Exam	17-01-2023	17-01-2023
8	2022-23	Seeking permission to college	28-12-2022	28-12-2022
9	2022-23	Seeking permission for Exam	28-08-2023	28-08-2023
10	2022-23	Seeking permission for Exam	14-04-2023	14-04-2023
11	2022-23	Seeking permission for Exam	13-07-2023	13-07-2023
12	2022-23	Seeking permission for ID card	24-07-2023	24-07-2023
13	2022-23	Seeking permission for ID card	25-05-2023	25-05-2023
14	2022-23	Seeking permission for formal dress	02-01-2023	02-01-2023
15	2022-23	Seeking permission for half day	19-01-2023	19-01-2023
16	2022-23	Seeking permission for duplicate Hall ticket	25-09-2023	25-09-2023
17	2022-23	Seeking permission for formal dress	16-07-2023	16-07-2023
18	2022-23	Seeking permission to college	05-04-2023	05-04-2023
19	2022-23	Seeking permission for half day leave	20-06-2023	20-06-2023

PRINCIPAL
Avanathi Institute of Engg. & Tech
Gunthapally (V), Abdullapurmet (Mdl), R.R. Dist.

Letter

Date: 18-11-22
Gunthapally.

To,

The Principal Sir,
Avanthi Institute of Engineering and Technology,
Gunthapally.

Respected sir,

Subject: Seeking permission to travel in
college bus at the time semester

I am B. Navshirreddy PIn NO 21065A0310

I want to travel in college bus to write final semester
due to long distance of travel.

So I am requesting you to give me permission to
travel in college bus.

Thanking you

Yours faithfully

B Navshirreddy

21065A0310

4th year
Mechanical

PRINCIPAL
Avanthi Institute of Engg. & Tech
Gunthapally (V), Abdullapurmet (M), R.R. Dist.

Letter

Date: 25/11/22
Grunthapally,

To,
The Respected
Principle Sir,

AVanthi Institute of Engineering and Technology,
Grunthapally.

Respected Sir,

Subject: Reauesting to travel in college
bus at the time of semester

I am R. Pallavi, Pin No: 21065A0324

Studying mechanical Engineering 3rd year

I want to travel in college bus to write final semester
Exams. So, please give permission to travel in college
bus.

Thanking you Sir.

Yours faithfully,

R. Pallavi

21065A0324

mechanical th

3rd year



PRINCIPAL
Avanthi Institute of Engg. & Tech
Grunthapally (V), Abdullapurmet (M), R.R. Dist.

date 23/07/2022

Gunthapally

To,

The respected principal sir

AVIT Gunthapally

(sub: ~~requesting~~ requesting to write the internal exams)

I am M. Monideep from Mechanical 2nd year

holding H.T No 22Q65A0304. I was absent during

Lab-internal exams. Due to health issues, please allow

to write the Lab-internal exams.

Thank you sir



yours sincerely

M. Monideep

H.T No, 22Q65A0304

PRINCIPAL
Avanathi Institute of Engg. & Tech
Gunthapally (V), Abdullapurmet (Mdl), R.R. Dist.

Date: 14-05-2022
Gunthapally.

To,
The Principal,
Avanathi Institute of Engg & Technology,
Gunthapally,
Ranga Reddy.

Sub: Request for Re-Exam of Lab
Internal Regards.

Respected Sir,

I Sourab Singh studying Mech II
year I sem in Mechanical Engg in AVIH Campus
Due to my health issue, i couldn't able to
write the Mose&MMS Lab Internal Exam.

I got Severe viral fever. I am Requesting you
to give the permission to write the Mose&MMS
Lab Internal Exam.

Thanking you,

Yours faithfully,
Sourab Singh
21061A0309
Mech-II year



PRINCIPAL
Avanathi Institute of Engg. & Tech.
Gunthapally (V), Abdullapuram (M), R.R. Dist.

Date: 10-03-2023

Gunthapally.

To,
The Principal,
Avanthi Inst. of Engg. Technology,
Gunthapally.

Sub: Seeking permission to allow mid I

Respected sir,

I B. Kavya studying B.Tech
I year in ECE Department in AVIH Campus Hyd.
Due to severe health problem, iam not able to
attend mid-I physics Exam. I was in Hospital
from last one week. so please give the
permission to Re-write Physics Internal Exam.

Thank you,

Yours faithfully,

B. Kavya,

HTNO: 22Q61A0403,

ECE Department

I-I Semester

PRINCIPAL
Avanthi Institute of Engg. & Tech
Gunthapally (V), Abdullapurmet (Mdl), R.R. Dist.

D. 15/03/2023

Gunthapally.

To,

The Principal,

AVIT,

Gunthapally

Subject: Seeking Permission to allow AP Lab Internal Exam.

Respected Sir,

I Ch. Ganesh - Studying B. Tech I year
in ECE Department in AVIT Campus Hyderabad.

Due to personal reasons I am unable to attend
the AP Lab Internal. So please give the permission to
Re-write Applied physics Lab Internal Exam.

Thank you.

Yours faithfully

Ch. Ganesh

HT. No: 22@61A045

ECE Department

I-I semester.

PRINCIPAL
Avanthi Institute of Engg. & Tech
Gunthapally (V), Abdullapurmet (Mdl), R.R. Dist.



AVANTHI INSTITUTE OF ENGINEERING AND TECHNOLOGY

(Approved by AICTE, Regg. By Govt. of T.S & Affiliated to JNTUH, Hyderabad)

NAAC "B++" Accredited Institute

Gunthapally (V), Abdullapurmet(M), RR Dist, Near Ramoji Film City, Hyderabad -501512.

www.aietg.ac.in email: principal.avanathi@gmail.com

CIRCULAR

The undersigned is organizing a meeting for all the members of Examinations and Evaluation Committee on 23 February at 2.30 pm in the college Conference hall to discuss the following points mentioned in the agenda.

Agenda:

- Discussion on conduction of II-II, III-II, IV-II internal and external examinations.
- Examination Circulars issued by JNTU-H.
- Consideration of late comers for Internal Examination.
- Re-Conducting Mid Examination.
- Issue of duplicate Hall ticket for External Examination.
- Any other points with the permission of the chairman.

PRINCIPAL

Copy to:

1. Principal office
2. All the members of Examinations and Evaluation Committee.
3. Office

PRINCIPAL
Avanathi Institute of Engg. & Tech
Abdullapurmet, RR Dist, Hyderabad



AVANTHI INSTITUTE OF ENGINEERING AND TECHNOLOGY

(Approved by AICTE, Recg. By Govt. of T.S & Affiliated to JNTUH, Hyderabad)

NAAC "B++" Accredited Institute

Gunthapally (V), Abdullapurmet(M), RR Dist, Near Ramoji Film City, Hyderabad -501512.

www.aietg.ac.in email: principal.avanthi@gmail.com

Minutes of Meeting

Examinations and Evaluation Committee meeting is conducted for the Academic year 2022-23 on 23 February at 2:30 p.m. in the Conference Hall to look into the complaints lodged by the students and to resolve such issues in the college.

Review of Action Taken:

Committee issued instructions to the concerned departments.

- **Item 1-** Discussion on conduction of II-II, III-II, IV-II internal and external examinations.

Resolution-In the wake of examinations, it was informed to all the faculty members to ensure that the students are completely prepared with their laboratory records, assignment books in time and to make students thorough to write their exams well.

- **Item 2-** Examination Circulars issued by JNTU-H.

Resolution-All the faculty members are informed to display on the notice board the timetables and the notifications issued by the university from time to time. The faculty members were also informed to take necessary steps for the smooth conduct of the examinations.

- **Item 3-** Re-Conducting of Mid Examination.

Resolution-Resolution As per the instructions given by the university, the members of the committee were against the violation of University norms and strictly informed the faculty members not to re-conduct the Internal Exams under any circumstances.

- **Item 4-** Consideration of late comers for Internal Examination.

Resolution- The College adheres to the university guidelines regarding the conduct of examinations. No late comer will be allowed to appear for the Internal examinations.

Item 5- Issue of duplicate Hall ticket for External Examination.

- **Resolution-**It was decided by the committee members and the same was conveyed to the examination cell to issue duplicate hall tickets to the needed student(s).

PRINCIPAL
Avanthi Institute of Engg & Tech
Gunthapally, RR Dist

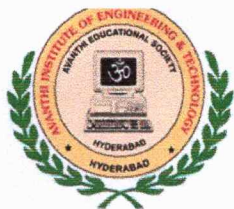

AVANTHI INSTITUTE OF ENGINEERING AND TECHNOLOGY

(Approved by AICTE, Recg. By Govt. of T.S & Affiliated to JNTUH, Hyderabad)

NAAC "B++" Accredited Institute

Gunthapally (V), Abdullapurmet(M), RR Dist, Near Ramoji Film City, Hyderabad -501512.

www.aietg.ac.in email: principal.avanthi@gmail.com

CONSTITUTION OF EXAMINATION COMMITTEE

Avanthi Institute of Engineering and Technology has constituted an examination committee to conduct examinations. The committee focuses on making policy decisions in regard to organizing and holding examinations, improving systems of examinations, moderations etc. and also preparing a schedule of internal examinations.

The examination committee deals with all the issues in relation to examinations and hears the complaints received pertaining to any subject arising out of the conduct of examinations and decides the course of action.

Examination committee has been constituted for the academic years 2022-23 as follows:

S.NO	FACULTY NAME	DESIGNATION	RESPONSIBILITY
1	Dr.G.Rama Chandra Reedy	Principal	Chair Person
2	M. Satish kumar	Controller of Examinations	Convener
3	M. Venkateshwarlu	Deputy controller of Examinations	Member
4	Dr. Kotte shailaja	Associate Professor	Member
5	Dr.Shakeerbasha shaik	Associate Professor	Member
6	Dr. S. Kishore Reddy	Associate Professor	Member
7	Dr.T.Kranthi Kumar	Associate Professor	Member
8	Dr.Y.Ramesh Babu	Associate Professor	Member

PRINCIPAL

Avanthi Institute of Engg. & Tech
Gunthapally (V), Abdullapurmet (M), R.R. Dist.



AVANTHI INSTITUTE OF ENGINEERING AND TECHNOLOGY

(Approved by AICTE, Regd. By Govt. of T.S & Affiliated to JNTUH, Hyderabad)

NAAC "B++" Accredited Institute

Gunthapally (V), Abdullapurmet(M), RR Dist, Near Ramoji Film City, Hyderabad -501512.

www.aietg.ac.in email: principal.avanathi@gmail.com

Functions of the Committee:

1. Collecting question banks for all the subjects within 2 weeks from the commencement of semester.
2. Computation of total requirement of invigilators for each examination.
3. Seating arrangements for internal and external examinations.
4. Conduct of external examinations (theory and practical)
5. Arranging dispatch of Answer Scripts bundles to JNTUH University.
6. Arranging required number of subject experts for evaluation at JNTUH University.
7. Downloading of question papers from university /external experts and printing, ensuring confidentiality.
8. Preparation of Result Analysis.
9. To interact with University for exam related works.
10. Preparation of remuneration bills of invigilators, examiners (Internals as well as External).
11. To review from time to time, the results of end semester examinations and forward reports thereon to the Principal.

PRINCIPAL

Copy to:
COE for kind information
All HOD, s
All the committee members

PRINCIPAL
Avanathi Institute of Engg. & Tech
Gunthapally (V), Abdullapurmet (M), R.R. Dist.

17-01-2022
Wednesday

TO
The Principal
Avanthi Institute of Technology
Gunthapally.

Sub:- Permission to Internal Exam.

To the Respected Sir.

I am G. Prasanna (22061A0564) From CSE B-tech.
1st year studying in our college. Since, I was suffering
from the fever. I dated for 20 minutes for internal exam.
So, please kindly grant me allowed to the permission of
Internal Exam

Thanking you Sir

PRINCIPAL
Avanthi Institute of Engg. & Tech
Gunthapally (V), Abdullapurmet (Mdl), R.R. Dist.

Yours Sincerely

G. Prasanna.

22061A0564

28/12/2022

To
The principal
AVIH
Gunthapally
Hyd

Sub:- 1/2 late due to RTC Brakedown

I am M. vijay kanth from csm 1st year
with roll no: 22061A06627. I was late due to RTC
breakdown please kindly give permission
Thankyou

your faithfully
M. vijay Kanth
22061A06627.



PRINCIPAL
Avanthi Institute of Engg. & Tech
Gunthapally (V), Abdullapurmet (Mdl), R.R. Dist.

Date 20/08/2018

Gunthapally

To

The respected principal sir

subjected ~~to~~ late permission to external exam

my self S. praveen MOOD from mechanical
ENGINEERING for 2nd year 2nd SEM today I am
was to come to college late due to some
strike so please give me permission to
write the lab external exam Thanking you sir

Yours obediently

S. praveen MOOD

21061A0303

PRINCIPAL

Avanthi Institute of Engg. & Tech
Gunthapally (V), Abdullapurmet (Md), R.R. Dist.

To,
The principal,
Avanthi institute of Engineering and Technology,
Guntthapally.

Date:- 14.
Place: Guntthapally

Respected sir,

SUB:- Requesting to write the Mid exam.

I am B. Swetha

Mechanical 4th year. I am late to the college 20 minutes
due to heavy traffic. So, please allow me to write the
mid exam.

Thanking you sir.

Yours faithfully,

Name: B. Swetha,

Roll No:- 21Q65A0308,

Mechanical 4th year.



PRINCIPAL

Avanthi Institute of Engg. & Tech
Guntthapally (V), Abdullapurmet (MD), R.R. Dist.

To,
The Respected
Principal Sir

Date: 13
Gunturhally

—Avanthi Institute of Engineering and Technology,
Subject: Requesting the Sir to re-conduct the
lab internal Exam

I am A22cm . Copying Pin no 21065A0325
pursuing mechanical branch of 4th year . I have
not attended the lab internal Exam - due to
family problems

So please re-schedule my lab internal
Exam

Yours faithfully
—A22cm
21065A0325



PRINCIPAL

Avanthi Institute of Engg. & Tech
Gunturhally (V), Abdullapurmet (M.C), R.R. Dist.

To,

Date:- 24-07-2023

The principal sir

AUIH.

Gunthapally

Hyderabad

Subject:- Permission for ID card missing.

I am B. Sai Teja studying B.tech 2nd year CSE with Roll no:- 22Q61A0509. Sir I missed my ID card please grant me permission.

Thanking you

Your faithfully

B. Sai Teja

CSE

22Q61A0509.

PRINCIPAL

Avanthi Institute of Engg. & Tech
Gunthapally (V), Abdullapurmet (Mdl), R.R. Dist.

Letter

Dt:- 25/5/2023

To
The principal sir
AVIH
Gunthapally
Hyderabad.

sub:- Requesting for ID card permission.

I am C. Saralatha from ECE 1st year roll no
(22061A0417). I am requesting you to give me
for one day because I forgot my id card.
So, please grant me to a permission for ID card.



PRINCIPAL
Avanthi Institute of Engg. & Tech
Gunthapally (V), Abdullapurmet (Md), R.R. Dist.

Yours faithfully
C. Saralatha
ECE 1st year
22061A0417.

Date : 2/1/2

To,

The principal
Avanthi collage (AVET)
Gunthapally

Sub:- Dress code permission

I A. Koushik bearing Roll.No 21261A0538
studying cse I year. Sir I want permission to wear
to dress because my college dress code will
missing so give me permission

Thank you

Yours lovingly

A. Koushik

PRINCIPAL
Avanthi Institute of Engg. & Tech
Gunthapally (V), Abdullapurmet (Mdl), R.R. Dist.

19-01-2023.

To
The principal sir

AVIH,
Gunthapally,
Hyderabad.

Sub:- Req to half day permission.

I am T. sravya from CSE - IInd year
(21861A0505) - I am requesting you to give me
half day permission because of health problem.
Please give me permission.

Thanking you

Yours faithfully,

T. sravya,
CSE - 2nd year

21861A0505

PRINCIPAL
Avanthi Institute of Engg. & Tech
Gunthapally (V), Abdullapurmet (Mdl), R.R. Dist.

Date: 25-09-2022

To
The principal
AVIT
Gunthapally
Hyderabad.

Sub: Issue of duplicate Hall Ticket

I am M. Ashok from EEE ¹th year with Roll No. 22Q61A0234. Sir I missed my hall ticket. please issue duplicate hall ticket. please grant me permission.

Thanking you

Yours faithfully
M. Ashok
EEE
22Q61A0234



PRINCIPAL
Avanathi Institute of Engg. & Tech
Gunthapally (V), Abdullapurmet (Mdl), R.R. Dist.

To,
The principal,
Avanthi Institute of Technology,
Gunthapally.

Date: 16/10/
Wednesday

Sub: Permission regarding the Dress code.

I am Ch. Varun of btech first year with the
rollno: 23061A0525. From CSE. Sir, kindly grant
me permission for this one day sir. due to heavy
rain.

Thanking you. Sir.



PRINCIPAL
Avanthi Institute of Engg. & Tech
Gunthapally (V), Abdullapurmet (Mdl), R.R. Dist.

Your
Obediently
Ch. Varun.
[23061A0525]
CSE btech.

Date: 05-04-2023

TO

The Principal,

Avanthi Institute of Engineering and Technology,
Gunthapally.

Sub: Seeking permission to college, Reg.

Respected sir,

I am K. Nithin, bearing my pin no 22Q61A0440,
I B.Tech ECE studying in our college. sir, Due to
TSRTC bus breakdown at Hayath Nagar, I could not
able to reach the college on time. Due to this
I am late by 20 min. please consider this lesson
and allow me to the class

Thanking you



PRINCIPAL
Avanthi Institute of Engg. & Tech
Gunthapally (V), Abdullapurmet (Md), R.R. Dist.

your faithfully,

K. Nithin,
22Q61A0440.

Letter

Date: 20-6

To,

The principal sir
AVIH
Gunthapally
Hyderabad

Sub: permission for half day leave.

I am M. Sakeeth CSE 1st year
I want half day leave because of health issue. So please
grant me permission.

Thanking you

yours faithfully
M. Sakeeth
CSE
22061A05C3



PRINCIPAL
Avanhi Institute of Engg. & Tech
Gunthapally (V), Abdullapurmet (Mdl), R.R. Dist.



Examination Reform Policy

November 2018

ALL INDIA COUNCIL FOR TECHNICAL EDUCATION
Nelson Mandela Marg, Vasant Kunj, New Delhi-110070

Examination Reform Policy

November 2018

MESSAGE

AICTE is taking a multi-pronged approach to recalibrate the technical education in the country, to provide competent professionals. Challenged by keeping the pace of education with the advancements in the technology and industry needs, AICTE has pushed reforms by way of a model curriculum for various engineering disciplines, providing good quality self-learning content through MOOCs, framing a policy for the training of technical teachers 3-week student induction program and enunciating guidelines for the mandatory internship for student among others. Continuing with the streak, AICTE has now come out with an Examination Reform Policy, which would not only improve the quality of technical education in general but also examine the effectiveness of earlier initiatives of AICTE and also those on the anvil.

Evaluation, grading and certification in our system rest on examinations which play an important role in the progression of a learner on the learning path. The examinations not only indicate whether the desired learning outcomes have been achieved but also assess the level of achievements against benchmarks. Thus, examinations serve as checkpoints for both the learner and the external world, allowing appropriate certification to be issued reflecting the proficiency of an individual operating in socio-economic spheres.

This policy comes at a time when knowledge is freely available for creating resources, opportunities for more knowledge, which requires skill of higher order beyond remembering and comprehension. This policy intends to push the evaluation notches up on the Bloom's taxonomy and examine the learner for higher order cognitive skills to drive critical thinking, creativity and problem solving which have to be the attributes of any technical professional. It is hoped that this will also force necessary alignment in the teaching-learning processes on one hand to the bridging of the gap between theory and practicals on the other and prepare students for innovation and creativity.

We request the technical institutions and universities in the country to adopt this examination reform policy. To facilitate this, model question papers and question banks will be developed/ shared through AICTE website. With a view to impart momentum to this much-awaited reform, AICTE shall be conducting a series of training workshops for faculty, across the country.

We thank members of the committee led by Prof. Shettar, Vice-Chancellor, KLE University for developing the policy which will go a long way to enhance the employability ratio and also enable youngsters to become problem-solvers, innovators and job creators. We especially thank MHRD for providing guidance and support throughout the process of creation of this Policy.

(Prof. Anil D. Sahasrabudhe)

PREFACE

Globalisation of the world economy and higher education are driving profound changes in engineering education system. Worldwide adaptation of Outcome-Based Education (OBE) framework and enhanced focus on higher-order learning and professional skills necessitates paradigm shift in traditional practices of curriculum design, education delivery and assessment. In recent years, worldwide sweeping reforms are being undertaken to bring about essential changes in engineering education in terms of what to teach (content) and how to teach (knowledge delivery) and how to assess (student learning).

Examinations/student assessments play a very important role in deciding the quality of education. The academic quality of examinations (question papers) in Indian engineering education system has been a matter of concern from a long time. This report attempts to bring out recommendations for reforms in examination system to meet challenges of emerging engineering education landscape.

The recommendations are presented in four sections. Beginning in Section-1, the most important drivers for examination reforms in Indian engineering education system are discussed. Section-2 brings out strategies to be adopted to align assessment with the desired student learning outcomes. A two-step method is proposed for mapping the examination questions with course outcomes. Section-3 highlights the necessity of designing question papers to test higher order abilities and skills. Application of blooms taxonomy framework to create an optimal structure of examination papers to test the different cognitive skills is discussed in detail. Challenge of assessing higher order abilities and professional skills through traditional examination system is brought out in Section-4. Several educational experiences and assessment opportunities are identified to overcome the challenges. Appendices contain the supplement material that is helpful for Universities/Colleges to implement recommendations.

At this juncture, reforms in examinations are critical for the improvement of the quality and relevance of Indian engineering education. It is hoped that the Report will be of use to Universities and Colleges to bring out the much-needed change. The cooperation received from AICTE officials in bringing out the Report is gratefully acknowledged.

Prof. Ashok S. Shettar

Prof. Rama Krishna Challa

Prof. Sanjay Agarwal

Prof. Upendra Pandel

ACKNOWLEDGEMENT

The development of an outcome based Examination Reform Policy for technical education is a result of thoughtful deliberations, involving dedicated and specialized experts. This Policy has been framed to meet the expectations of an academically challenging environment, develop problem-solving skills by students, aligning with current global standards and to enrich the students learning to make them self-enablers and/or match job requirements on successful completion of their degree.

The performance-based new-age reforms in the examination will benefit each student for preparing him/her for success in the knowledge society. This will create proper mapping between program outcomes and assessment tools that lead to the accurate and reliable measurement of attainment of outcomes of the students. In short, the Policy focuses on providing the ability of student to understand the subject and apply the knowledge to real world problems.

We are thankful to the members of the committee Prof. Ashok S. Shettar, Prof. Rama Krishna Challa, Prof. Sanjay Agarwal and Prof. Upendra Pandel who were devotedly committed towards framing this Policy. We thank them for identifying Competencies and Performance Indicators (PIs) with Program Outcomes (POs); Sample Questions for all six levels of Bloom's Taxonomy; Model Question Papers for end semester examinations based on Bloom's Taxonomy; and Sample Scoring Rubrics for communication (written & oral), and assessment of design projects and semester mini projects.

Special thanks and gratitude to Prof. Anil D. Sahasrabdhe, Chairman; Prof M.P. Poonia, Vice Chairman and Prof. A.P. Mittal, Member Secretary, AICTE who have been pivotal in developing this Policy and encouraging throughout the process.

I appreciate the officers and officials of Policy & Academic Planning Bureau for their contribution and support in the exercise that has led to this Policy.

I also sincerely thank all officers and officials of AICTE, who have contributed in one way or other for the development of this Policy.

Thanking all once again and seeking continued support and also feedback on the Policy.

(Prof. Rajive Kumar)

Adviser-I

Policy & Academic Planning Bureau, AICTE

TABLE OF CONTENTS

	Page No.
1 Introduction	11
2 Assessment Strategy for Outcome Based Education (OBE)	13
2.1 Mapping Program Outcomes (POs) to Assessment (Examinations)	13
2.2 Two-step Process for Bringing Clarity to POs	13
2.3 Program Outcomes -Competencies – Performance Indicators (PIs)	15
3 Improving Structure and Quality of Assessments	21
3.1 Bloom’s Taxonomy for Assessment Design	21
3.2 Action Verbs for Assessment	22
3.3 Assessment Planning	23
4 Assessing Higher-order Abilities & Professional Skills	25
4.1 Innovative Educational Experiences to Teach and Assess	25
4.2 Using Scoring Rubrics as Assessment Tool	25
4.3 Open-Book Examinations	26
APPENDIX-A	29
Competencies and PIs	
Computer Science/Information Science Programs	
APPENDIX-B	35
Sample Questions for Bloom’s Taxonomy Levels	
APPENDIX-C	41
Model Question Papers	
APPENDIX-D	47
Sample Scoring Rubrics	

INTRODUCTION

Globalisation of the world economy and higher education are driving profound changes in engineering education system. There is a continuing need to dynamically adapt to these changes, to ensure that we remain competitive and can respond effectively to the challenges of globalisation. Future engineering graduates not only need to be knowledgeable in his/her discipline but also needs a new set of soft, professional skills and competencies [1].

In recent years, there have been essential changes in engineering education in terms of what to teach (content) and how to teach (knowledge delivery) and how to assess (student learning).

AICTE has already taken initiation to come out with model curriculum for engineering programs. The digital initiatives of MHRD and AICTE have made available very large number of MOOC courses through SWAYAM, that can help the colleges and teachers to adopt innovative methodologies in the delivery of course.

The present report focusses on the recommendations for reforms in examinations (assessment of student) in the context of emerging landscape of engineering education.

Examinations/student assessments play a very important role in deciding the quality of education. They must not only assess student's achievements (and grades) but also measure whether the desired learning outcomes have been achieved. The achievement of objectives and program outcomes are crucial and needs to be proven through accurate and reliable assessments.

The academic quality of examinations (question papers) in Indian engineering education system has been a matter of concern from a long time. It is widely acknowledged that “assessment drives learning”, what and how students learn depends to a major extent on how they think they will be assessed [2]. The question papers that require simple memory recall will not ensure deep, meaningful learning. High expectations for learning motivate the students to rise to the occasion. The assessment (examination) must embed those high expectations to ensure that the learner is motivated to attain them.

Considering the above imperatives, it is clear that reforms in Examinations are critical for improvement of the quality of Indian engineering education. The most important drivers for reforms in examination system of Indian engineering education are:

1. Adaptation of Outcome-Based Education Framework

Outcome-based education (OBE)- a performance-based approach has emerged as a major reform model in the global engineering education scenario [3]. The country that wants to be a signatory member of a multinational agreement for the mutual recognition of engineering degrees, i.e. the Washington Accord (WA) must implement OBE. This will be an endorsement that the engineering education system has demonstrated a strong, long-term commitment to quality assurance in producing engineers ready for industry practice in the international scene. Being signatory to the Washington Accord, Indian accreditation agency 'National Board of Accreditation (NBA)' has made it mandatory for engineering institutions to adapt OBE framework for their curriculum design, delivery and assessment. In OBE framework, the educational outcomes of a program are clearly and unambiguously specified. These determine the curriculum content and its organization, the teaching methods and strategies and the assessment process.

Though Indian Universities and Colleges have started adapting OBE framework for their engineering programs, the focus is limited to the curriculum design part, i.e. connecting curriculum components to the program outcomes. Very little attention is being given for connecting examination questions/assessment tools to the program outcomes. The absence of proper mapping between program outcomes and assessment tools lead to the inaccurate and unreliable measurement of attainment of outcomes by the students. This missing connect creates a big gap in the effective adaptation of OBE framework, making the whole exercise futile.

2. Importance of Higher-order Abilities and Professional Skills

In the present examination system, memorization occupies a dominant place. The recall of factual knowledge, though essential to any examination, is only one of several major abilities to be demonstrated by the graduates. The assessment process must also test higher level skills viz. ability to apply knowledge, solve complex problems, analyse, synthesise and design. Further, professional skills like the ability to communicate, work in teams, lifelong learning have become important elements for employability of the graduates [4]. It is important that the examinations also give appropriate weightage to the assessment of these higher-level skills and professional competencies.

Keeping in view of the above challenges and looking at some of the worldwide best practices in assessment, the present report comes up with several recommendations that can be used by Universities/Colleges to design their assessment strategies.

ASSESSMENT STRATEGY FOR OUTCOME-BASED EDUCATION

1. Mapping Program Outcomes to Assessment (Examinations)

Graduate attributes (GAs) articulate the generic abilities to be looked for in a graduate of any undergraduate degree program. They form the Program Outcomes (POs) that reflect the skills, knowledge and abilities of graduates regardless of the field of study. This does not mean that POs are necessarily independent of disciplinary knowledge –rather, these qualities may be developed in various disciplinary contexts.

In outcome-based education, a “design down” process is employed which moves from POs to Course Outcomes (COs) and outcomes for individual learning experiences. Outcomes at each successive level need to be aligned with, and contribute to, the program outcomes.

Courses are the building blocks of a program. Teaching strategies, learning activities, assessments and resources should all be designed and organized to help students achieve the learning outcomes at the course level. In the assessment activities, students demonstrate their level of achievement of the course learning outcomes. In a constructively aligned program, the courses are carefully coordinated to ensure steady development or scaffolding from the introduction to mastery of the learning outcomes, leading to achievement of the intended POs. For the effectiveness of the program, the achievement of POs is crucial which needs to be proven through accurate and reliable assessments.

2. Two-step Process for Bringing Clarity to POs

POs give useful guidance at the program level for the curriculum design, delivery and assessment of student learning. However, they represent fairly high-level generic goals that are not directly measurable. Real observability and measurability of the POs at course level is very difficult. To connect high-level learning outcomes (POs) with course content, course outcomes and assessment, there is a necessity to bring further clarity and specificity to the program outcomes [5]. This can be achieved through the following two-step process of identifying Competencies and Performance Indicators (PI).

- (1) Identify Competencies to be attained: For each PO define competencies –different abilities implied by program outcome statement that would generally require different assessment measures. This helps us to create a shared understanding of the competencies we want students to achieve. They serve as an intermediate step to the creation of measurable indicators.

Example:

Program Outcome (Attribute 3)

Design:

PO3: Design/Development of Solutions: Design solutions for complex engineering problems and

design system components or processes that meet the specified needs with appropriate consideration for public health and safety, and cultural, societal, and environmental considerations.

Competencies

1. Demonstrate an ability to define a complex, open-ended problem in engineering terms.
 2. Demonstrate an ability to generate a diverse set of alternative design solutions.
 3. Demonstrate an ability to select the optimal design scheme for further development.
 4. Demonstrate an ability to advance an engineering design to the defined end state.
- (2) Define Performance Indicators: For each of the competencies identified, define performance Indicators (PIs) that are explicit statements of expectations of the student learning. They can act as measuring tools in assessment to understand the extent of attainment of outcomes. They can also be designed to determine the appropriate achievement level or competency of each indicator so that instructors can target and students can achieve the acceptable level of proficiency.

Example:

For the Competency -2

Demonstrate an ability to generate a diverse set of alternative design solutions

Performance Indicators:

1. Apply formal idea generation tools to develop multiple engineering design solutions
2. Build models, prototypes, algorithms to develop a diverse set of design solutions
3. Identify the functional and non-functional criteria for evaluation of alternate design solutions.

It should be noted that, when we consider the program outcome, it looks like, it can be achieved only in the Capstone project. But if we consider the competencies and performance indicators, we start seeing the opportunities of addressing them (and hence PO) in various courses of the program.

Once the above process is completed for the program, the assessment of COs for all the courses is designed by connecting assessment questions (used in various assessment tools) to the PIs. By following this process, where examination questions map with PIs, we get clarity and better resolution for the assessment of COs and POs. The pictorial representation of the process is given in Fig. 1

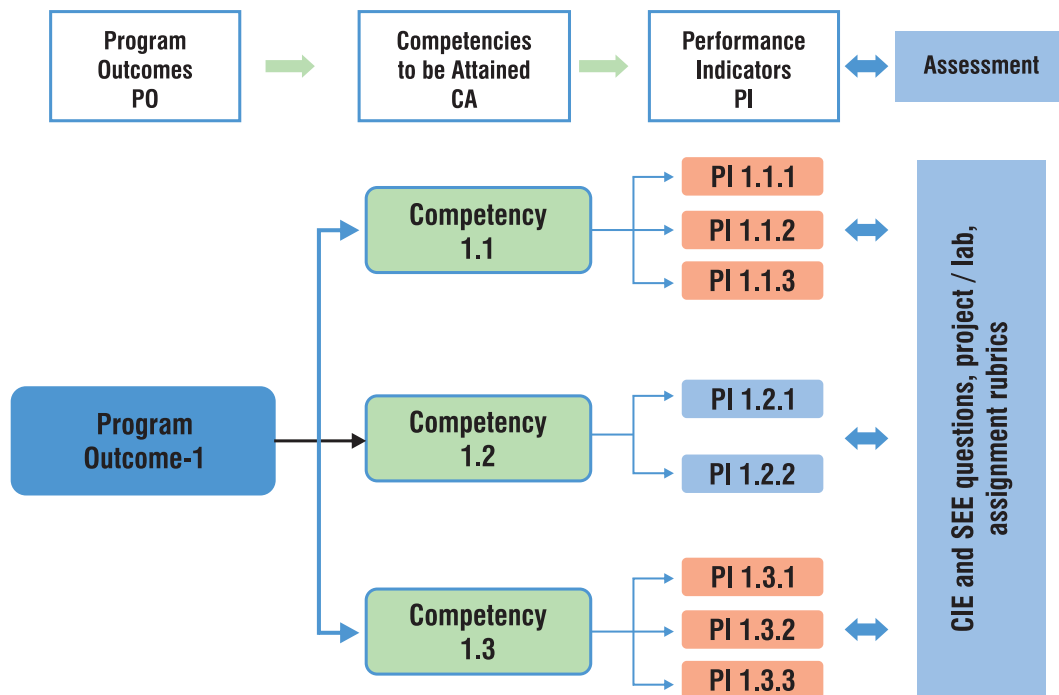

Fig. 1: Connecting POs to Assessment

3. Program Outcomes – Competencies – Performance Indicators

Following table gives the suggestive list of competencies and associated performance indicators for each of the PO in Mechanical Engineering Program.

PO 1: Engineering knowledge: Apply the knowledge of mathematics, science, engineering fundamentals, and an engineering specialisation for the solution of complex engineering problems.	
Competency	Indicators
1.1 Demonstrate competence in mathematical modelling	1.1.1 Apply mathematical techniques such as calculus, linear algebra, and statistics to solve problems 1.1.2 Apply advanced mathematical techniques to model and solve mechanical engineering problems
1.2 Demonstrate competence in basic sciences	1.2.1 Apply laws of natural science to an engineering problem
1.3 Demonstrate competence in engineering fundamentals	1.3.1 Apply fundamental engineering concepts to solve engineering problems
1.4 Demonstrate competence in specialized engineering knowledge to the program	1.4.1 Apply Mechanical engineering concepts to solve engineering problems.
PO 2: Problem analysis: Identify, formulate, research literature, and analyse complex engineering problems reaching substantiated conclusions using first principles of mathematics, natural sciences, and engineering sciences.	
Competency	Indicators
2.1 Demonstrate an ability to identify and formulate complex engineering problem	2.1.1 Articulate problem statements and identify objectives 2.1.2 Identify engineering systems, variables, and parameters to solve the problems 2.1.3 Identify the mathematical, engineering and other relevant knowledge that applies to a given problem

2.2	Demonstrate an ability to formulate a solution plan and methodology for an engineering problem	2.2.1 Reframe complex problems into interconnected sub-problems 2.2.2 Identify, assemble and evaluate information and resources. 2.2.3 Identify existing processes/solution methods for solving the problem, including forming justified approximations and assumptions 2.2.4 Compare and contrast alternative solution processes to select the best process.
2.3	Demonstrate an ability to formulate and interpret a model	2.3.1 Combine scientific principles and engineering concepts to formulate model/s (mathematical or otherwise) of a system or process that is appropriate in terms of applicability and required accuracy. 2.3.2 Identify assumptions (mathematical and physical) necessary to allow modeling of a system at the level of accuracy required.
2.4	Demonstrate an ability to execute a solution process and analyze results	2.4.1 Apply engineering mathematics and computations to solve mathematical models 2.4.2 Produce and validate results through skilful use of contemporary engineering tools and models 2.4.3 Identify sources of error in the solution process, and limitations of the solution. 2.4.4 Extract desired understanding and conclusions consistent with objectives and limitations of the analysis

PO 3: Design/Development of Solutions: Design solutions for complex engineering problems and design system components or processes that meet the specified needs with appropriate consideration for public health and safety, and cultural, societal, and environmental considerations.

Competency		Indicators	
3.1	Demonstrate an ability to define a complex/open-ended problem in engineering terms	3.1.1 Recognize that need analysis is key to good problem definition 3.1.2 Elicit and document, engineering requirements from stakeholders 3.1.3 Synthesize engineering requirements from a review of the state-of-the-art 3.1.4 Extract engineering requirements from relevant engineering Codes and Standards such as ASME, ASTM, BIS, ISO and ASHRAE. 3.1.5 Explore and synthesize engineering requirements considering health, safety risks, environmental, cultural and societal issues 3.1.6 Determine design objectives, functional requirements and arrive at specifications	
3.2	Demonstrate an ability to generate a diverse set of alternative design solutions	3.2.1 Apply formal idea generation tools to develop multiple engineering design solutions 3.2.2 Build models/prototypes to develop a diverse set of design solutions 3.2.3 Identify suitable criteria for the evaluation of alternate design solutions	
3.3	Demonstrate an ability to select an optimal design scheme for further development	3.3.1 Apply formal decision-making tools to select optimal engineering design solutions for further development 3.3.2 Consult with domain experts and stakeholders to select candidate engineering design solution for further development	
3.4	Demonstrate an ability to advance an engineering design to defined end state	3.4.1 Refine a conceptual design into a detailed design within the existing constraints (of the resources) 3.4.2 Generate information through appropriate tests to improve or revise the design	

PO 4: Conduct investigations of complex problems: Use research-based knowledge and research methods including design of experiments, analysis and interpretation of data, and synthesis of the information to provide valid conclusions.

Competency		Indicators	
4.1	Demonstrate an ability to conduct investigations of technical issues consistent with their level of knowledge and understanding	4.1.1 Define a problem, its scope and importance for purposes of investigation 4.1.2 Examine the relevant methods, tools and techniques of experiment design, system calibration, data acquisition, analysis and presentation 4.1.3 Apply appropriate instrumentation and/or software tools to make measurements of physical quantities 4.1.4 Establish a relationship between measured data and underlying physical principles.	

4.2	Demonstrate an ability to design experiments to solve open-ended problems	4.2.1 Design and develop an experimental approach, specify appropriate equipment and procedures 4.2.2 Understand the importance of the statistical design of experiments and choose an appropriate experimental design plan based on the study objectives
4.3	Demonstrate an ability to analyze data and reach a valid conclusion	4.3.1 Use appropriate procedures, tools and techniques to conduct experiments and collect data 4.3.2 Analyze data for trends and correlations, stating possible errors and limitations 4.3.3 Represent data (in tabular and/or graphical forms) so as to facilitate analysis and explanation of the data, and drawing of conclusions 4.3.4 Synthesize information and knowledge about the problem from the raw data to reach appropriate conclusions

PO 5: Modern tool usage: Create, select, and apply appropriate techniques, resources, and modern engineering and IT tools including prediction and modelling to complex engineering activities with an understanding of the limitations.

Competency		Indicators
5.1	Demonstrate an ability to identify/ create modern engineering tools, techniques and resources	5.1.1 Identify modern engineering tools such as computer-aided drafting, modeling and analysis; techniques and resources for engineering activities 5.1.2 Create/adapt/modify/extend tools and techniques to solve engineering problems
5.2	Demonstrate an ability to select and apply discipline-specific tools, techniques and resources	5.2.1 Identify the strengths and limitations of tools for (i) acquiring information, (ii) modeling and simulating, (iii) monitoring system performance, and (iv) creating engineering designs. 5.2.2 Demonstrate proficiency in using discipline-specific tools
5.3	Demonstrate an ability to evaluate the suitability and limitations of tools used to solve an engineering problem	5.3.1 Discuss limitations and validate tools, techniques and resources 5.3.2 Verify the credibility of results from tool use with reference to the accuracy and limitations, and the assumptions inherent in their use.

PO 6: The engineer and society: Apply reasoning informed by the contextual knowledge to assess societal, health, safety, legal, and cultural issues and the consequent responsibilities relevant to the professional engineering practice.

Competency		Indicators
6.1	Demonstrate an ability to describe engineering roles in a broader context, e.g. pertaining to the environment, health, safety, legal and public welfare	6.1.1 Identify and describe various engineering roles; particularly as pertains to protection of the public and public interest at the global, regional and local level
6.2	Demonstrate an understanding of professional engineering regulations, legislation and standards	6.2.1 Interpret legislation, regulations, codes, and standards relevant to your discipline and explain its contribution to the protection of the public

PO 7: Environment and sustainability: Understand the impact of the professional engineering solutions in societal and environmental contexts, and demonstrate the knowledge of, and the need for sustainable development.

Competency		Indicators
7.1	Demonstrate an understanding of the impact of engineering and industrial practices on social, environmental and in economic contexts	7.1.1 Identify risks/impacts in the life-cycle of an engineering product or activity 7.1.2 Understand the relationship between the technical, socio-economic and environmental dimensions of sustainability

7.2	Demonstrate an ability to apply principles of sustainable design and development	7.2.1 Describe management techniques for sustainable development 7.2.2 Apply principles of preventive engineering and sustainable development to an engineering activity or product relevant to the discipline
PO 8: Ethics: Apply ethical principles and commit to professional ethics and responsibilities and norms of the engineering practice.		
Competency		Indicators
8.1	Demonstrate an ability to recognize ethical dilemmas	8.1.1 Identify situations of unethical professional conduct and propose ethical alternatives
8.2	Demonstrate an ability to apply the Code of Ethics	8.2.1 Identify tenets of the ASME professional code of ethics 8.2.2 Examine and apply moral & ethical principles to known case studies
PO 9: Individual and team work: Function effectively as an individual, and as a member or leader in diverse teams, and in multidisciplinary settings.		
Competency		Indicators
9.1	Demonstrate an ability to form a team and define a role for each member	9.1.1 Recognize a variety of working and learning preferences; appreciate the value of diversity on a team 9.1.2 Implement the norms of practice (e.g. rules, roles, charters, agendas, etc.) of effective team work, to accomplish a goal.
9.2	Demonstrate effective individual and team operations--communication, problem-solving, conflict resolution and leadership skills	9.2.1 Demonstrate effective communication, problem-solving, conflict resolution and leadership skills 9.2.2 Treat other team members respectfully 9.2.3 Listen to other members 9.2.4 Maintain composure in difficult situations
9.3	Demonstrate success in a team-based project	9.3.1 Present results as a team, with smooth integration of contributions from all individual efforts
PO 10: Communication: Communicate effectively on complex engineering activities with the engineering community and with the society at large, such as being able to comprehend and write effective reports and design documentation, make effective presentations, and give and receive clear instructions		
Competency		Indicators
10.1	Demonstrate an ability to comprehend technical literature and document project work	10.1.1 Read, understand and interpret technical and non-technical information 10.1.2 Produce clear, well-constructed, and well-supported written engineering documents 10.1.3 Create flow in a document or presentation - a logical progression of ideas so that the main point is clear
10.2	Demonstrate competence in listening, speaking, and presentation	10.2.1 Listen to and comprehend information, instructions, and viewpoints of others 10.2.2 Deliver effective oral presentations to technical and non-technical audiences
10.3	Demonstrate the ability to integrate different modes of communication	10.3.1 Create engineering-standard figures, reports and drawings to complement writing and presentations 10.3.2 Use a variety of media effectively to convey a message in a document or a presentation

PO 11: Project management and finance: Demonstrate knowledge and understanding of the engineering and management principles and apply these to one's work, as a member and leader in a team, to manage projects and in multidisciplinary environments.

Competency	Indicators
11.1 Demonstrate an ability to evaluate the economic and financial performance of an engineering activity	11.1.1 Describe various economic and financial costs/benefits of an engineering activity 11.1.2 Analyze different forms of financial statements to evaluate the financial status of an engineering project
11.2 Demonstrate an ability to compare and contrast the costs/benefits of alternate proposals for an engineering activity	11.2.1 Analyze and select the most appropriate proposal based on economic and financial considerations.
11.3 Demonstrate an ability to plan/manage an engineering activity within time and budget constraints	11.3.1 Identify the tasks required to complete an engineering activity, and the resources required to complete the tasks. 11.3.2 Use project management tools to schedule an engineering project, so it is completed on time and on budget.

PO 12: Life-long learning: Recognise the need for, and have the preparation and ability to engage in independent and life-long learning in the broadest context of technological change.

Competency	Indicators
12.1 Demonstrate an ability to identify gaps in knowledge and a strategy to close these gaps	12.1.1 Describe the rationale for the requirement for continuing professional development 12.1.2 Identify deficiencies or gaps in knowledge and demonstrate an ability to source information to close this gap
12.2 Demonstrate an ability to identify changing trends in engineering knowledge and practice	12.2.1 Identify historic points of technological advance in engineering that required practitioners to seek education in order to stay current 12.2.2 Recognize the need and be able to clearly explain why it is vitally important to keep current regarding new developments in your field
12.3 Demonstrate an ability to identify and access sources for new information	12.3.1 Source and comprehend technical literature and other credible sources of information 12.3.2 Analyze sourced technical and popular information for feasibility, viability, sustainability, etc.

The above table can be used for most of the engineering programs. However, for Computer Science & Engineering/ Information Technology programs it requires some modifications.

A suggestive list of competencies and associated performance indicators for Computer Science & Engineering/ Information Technology Programs is given in Appendix- A.

IMPROVING STRUCTURE AND QUALITY OF ASSESSMENTS

For improving the structure and quality of assessment in various engineering programs following points need to be remembered:

1. In Indian engineering education system, written examinations play a major role in assessing the learning and awarding of grades to the student. Universities and colleges give highest weightage to the outcomes of the written examinations in overall grading. Questions raised in the examination/test papers play an important role in defining the level of learning the student is expected to achieve in the courses and hence in the program. Since assessment drives learning, the design of question papers needs to go beyond the mere test of memory recall. They also need to test higher-order abilities and skills.
2. Written examinations assess a very limited range of outcomes and cognitive levels. Particularly in the courses, where course outcomes (COs) cover a broad range of expectations, written examinations alone will not be sufficient to make valid judgements about student learning. A wide range of assessment methods (e.g., term papers, open-ended problem-solving assignments, course/lab project rubrics, portfolios etc.) need to be employed to ensure that assessment methods match with learning outcomes.
3. It is advisable to formulate assessment plans for each of the course in the program that brings clarity to the following:
 - a. Alignment of assessment with learning outcome of the course
 - b. Level of learning (cognitive) student is expected to achieve
 - c. Assessment method to be adapted

The method to align examination questions/assessment to COs and hence POs was discussed in the section-1. The following sections discuss the application of Bloom's taxonomy framework to create the optimal structure of examination papers to test the different cognitive skills.

1. Bloom's Taxonomy for Assessment Design

Bloom's Taxonomy provides an important framework to not only design curriculum and teaching methodologies but also to design appropriate examination questions belonging to various cognitive levels. Bloom's Taxonomy of Educational Objectives developed in 1956 by Benjamin Bloom [6] was widely accepted by educators for curriculum design and assessment. In 2001, Anderson and Krathwohl modified Bloom's taxonomy [7] to make it relevant to the present-day requirements. It attempts to divide learning into three types of domains (cognitive, affective, and behavioural) and then defines the level of performance for each domain. Conscious efforts to map the curriculum and assessment to these levels can help the programs to aim for higher-level abilities which go beyond remembering or understanding, and require application, analysis, evaluation or creation.

Revised Bloom’s taxonomy in the cognitive domain includes thinking, knowledge, and application of knowledge. It is a popular framework in engineering education to structure the assessment as it characterizes complexity and higher-order abilities. It identifies six levels of competencies within the cognitive domain (Fig. 2) which are appropriate for the purposes of engineering educators.

According to revised Bloom’s taxonomy, the levels in the cognitive domain are as follows:

Level	Descriptor	Level of attainment
1	Remembering	Recalling from the memory of the previously learned material
2	Understanding	Explaining ideas or concepts
3	Applying	Using the information in another familiar situation
4	Analysing	Breaking information into the part to explore understandings and relationships
5	Evaluating	Justifying a decision or course of action
6	Creating	Generating new ideas, products or new ways of viewing things

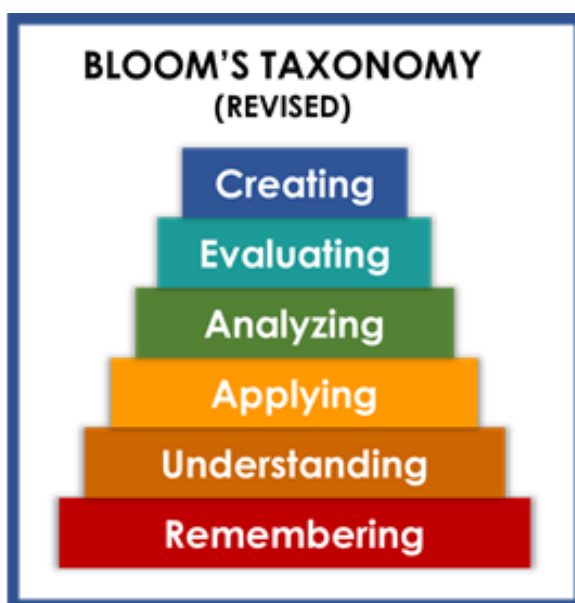

Fig. 2: Revised Bloom’s Taxonomy

Bloom’s taxonomy is hierarchical, meaning that learning at the higher level requires that skills at a lower level are attained.

2. Action Verbs for Assessment

Choice of action verbs in constructing assessment questions is important to consider. Quite often, the action verbs are indicators of the complexity (level) of the question. Over time, educators have come up with a taxonomy of measurable verbs corresponding to each of the Bloom’s cognitive levels [8]. These verbs help us not only to describe and classify observable knowledge, skills and abilities but also to frame the examination or assignment questions that are appropriate to the level we are trying to assess.

Suggestive list of skills/ competencies to be demonstrated at each of the Bloom’s level and corresponding cues/ verbs for the examination/ test questions is given below:

Level	Skill Demonstrated	Question cues / Verbs for tests
1. Remember	<ul style="list-style-type: none"> Ability to recall of information like facts, conventions, definitions, jargon, technical terms, classifications, categories, and criteria ability to recall methodology and procedures, abstractions, principles, and theories in the field knowledge of dates, events, places mastery of subject matter 	list, define, tell, describe, recite, recall, identify, show, label, tabulate, quote, name, who, when, where
2. Understand	<ul style="list-style-type: none"> understanding information grasp meaning translate knowledge into new context interpret facts, compare, contrast order, group, infer causes predict consequences 	describe, explain, paraphrase, restate, associate, contrast, summarize, differentiate interpret, discuss
3. Apply	<ul style="list-style-type: none"> use information use methods, concepts, laws, theories in new situations solve problems using required skills or knowledge Demonstrating correct usage of a method or procedure 	calculate, predict, apply, solve, illustrate, use, demonstrate, determine, model, experiment, show, examine, modify
4. Analyse	<ul style="list-style-type: none"> break down a complex problem into parts Identify the relationships and interaction between the different parts of a complex problem identify the missing information, sometimes the redundant information and the contradictory information, if any 	classify, outline, break down, categorize, analyze, diagram, illustrate, infer, select
5. Evaluate	<ul style="list-style-type: none"> compare and discriminate between ideas assess value of theories, presentations make choices based on reasoned argument verify value of evidence recognize subjectivity use of definite criteria for judgments 	assess, decide, choose, rank, grade, test, measure, defend, recommend, convince, select, judge, support, conclude, argue, justify, compare, summarize, evaluate
6. Create	<ul style="list-style-type: none"> use old ideas to create new ones Combine parts to make (new) whole, generalize from given facts relate knowledge from several areas predict, draw conclusions 	design, formulate, build, invent, create, compose, generate, derive, modify, develop, integrate

It may be noted that some of the verbs in the above table are associated with multiple Bloom's Taxonomy levels. These verbs are actions that could apply to different activities. We need to keep in mind that it's the skill, action or activity we need students to demonstrate that will determine the contextual meaning of the verb used in the assessment question.

3. Assessment Planning

While using Bloom's taxonomy framework in planning and designing of assessment of student learning, following points need to be considered:

1. Normally the first three learning levels; remembering, understanding and applying and to some extent fourth level analysing are assessed in the Continuous Internal Evaluation (CIE) and Semester End

Examinations (SEE), where students are given a limited amount of time. And abilities; analysis, evaluation and creation can be assessed in extended course works or in a variety of student works like course projects, mini/ minor projects, internship experience and final year projects.

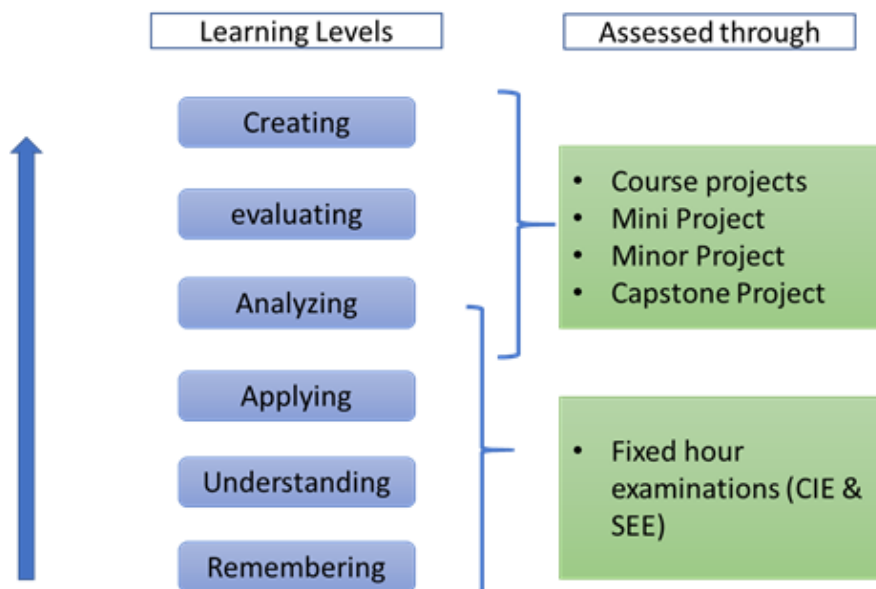

Fig. 3: Assessment methods for different Bloom's cognitive levels

2. Before adopting this framework for reforms in examination system of a University/Institution, it is worthwhile to study the present pattern of assessment in each of the course in the program to gain insight about:
 - a) Alignment of assessment questions with course learning outcomes
 - b) Whether all the learning outcomes are tested; sometimes some learning outcomes are over tested at the expense of others which may be not tested at all.
 - c) Overall weightage in the assessment, to each of Bloom's learning levels
 - d) Assessment methods used to adequately assess the content and desired learning outcomes

Based on the study, improvement priorities for each of the above factors need to be arrived at. The reform process needs to be well planned and implemented through institutional strategy and communicated to all stakeholders particularly to the students.

3. A good and reasonable examination paper must consist of various difficulty levels to accommodate the different capabilities of students. Bloom's taxonomy framework helps the faculty to set examination papers that are well balanced, testing the different cognitive skills without a tilt towards a tough or easy paper perception. If the present examination questions are more focused towards lower cognitive skills, conscious efforts need to be made to bring in application skills or higher cognitive skills in the assessment. It is recommended that at institution/ University level, upper limit need to be arrived for lower order skills (for example, no more than 40% weightage for knowledge-oriented questions). It is important to note that, as nature of every course is different, the weightage for different cognitive levels in the question papers can also vary from course to course.
 - Examples of typical questions for each of Bloom's cognitive level are given in Appendix-B
 - Model Question Papers are given in Appendix- C

ASSESSING HIGHER-ORDER ABILITIES & PROFESSIONAL SKILLS

In the 21st century, professional skills (also known as soft skills, generic skills or transferable skills) have emerged as important attributes of a graduate engineer. Studies show that Industry/ employers around the world value these abilities more than the disciplinary knowledge. This is also reflected in the NBA graduate attributes wherein six out of twelve attributes belong to this category, viz. (1) communication, (2) teamwork, (3) understanding ethics and professionalism, (4) understanding global and societal contexts, (5) lifelong learning, and (6) knowledge of contemporary issues. Further, higher-order cognitive abilities like critical thinking, problem-solving and making informed decisions are also crucial for a graduate to succeed in the emerging world. Though the employers consider these professional skills and higher abilities as important, students are weak in them. The main challenge surrounding them is that they are difficult to assess through existing conventional examination system.

1. Innovative Educational Experiences to Teach and Assess

One of the main obstacles in addressing these outcomes is the limitation of educational experience we create within our engineering programs. Most of the coursework in our programs are oriented towards teaching technical knowledge and skills; hence, the assessment is limited to those abilities. However, acquiring the professional outcomes may not result simply from participation in a particular class or set of classes. Rather, these outcomes are more often acquired or influenced through sources both in and outside the classroom [4].

To address these challenges, comprehensive reforms are needed in the way we design our curriculum, student learning experiences and assessment of the outcomes. Worldwide several attempts are being made to address these challenges. Following are the few educational experiences that are recommended to teach and assess professional outcomes and higher-order cognitive abilities:

- Course projects
- Open-ended experiments in laboratories
- Project-based learning modules
- MOOCs
- Co-Curricular experiences
- Mini / Minor projects
- Final year projects
- Internship experiences
- E-portfolios of student works

2. Using Scoring Rubrics as Assessment Tool

To evaluate the above, student works for attainment of course outcomes and hence POs, it is of

utmost importance to have reliable methods / proper assessment tools. Rubrics provide a powerful tool for assessment and grading of student work. They can also serve as a transparent and inspiring guide to learning. Rubrics are scoring, or grading tool used to measure a students' performance and learning across a set of criteria and objectives. Rubrics communicate to students (and to other markers) your expectations in the assessment, and what you consider important.

There are three components within rubrics namely (i) criteria / performance Indicator: the aspects of performance that will be assessed, (ii) descriptors: characteristics that are associated with each dimension, and (iii) scale/level of performance: a rating scale that defines students' level of mastery within each criterion.

Communication Skills				
	Unsatisfactory 1	Developing 2	Satisfactory 3	Exemplary 4
Performance criteria				
Performance criteria				
Performance criteria				
Performance criteria				
	Descriptors			

Fig. 4: Examples of Rubrics (Accessed from Rogers 2010)

3. Open-Book Examinations

In the earlier sections it was noted that the traditional written examinations have a significant weakness that they tend to encourage rote learning and more superficial application of knowledge. This deficiency can be overcome by “open-book examination”. Open-book examination is similar to time constrained written examinations but designed in a way that allows students to refer to either class notes, textbooks, or other approved material while answering questions. They are particularly useful if you want to test skills in application, analysis and evaluation, i.e. higher levels of Bloom’s taxonomy. However, in a program, the courses or the curriculum areas that are best suited to an open-book exam are to be carefully chosen.

Advantages of open-book examinations

1. Less demanding on memory and hence less stressful
2. Questions can emphasise more on problem-solving, application of knowledge and higher-order thinking rather than simple recall of facts.
3. Assessment questions can reflect real-life situations that require comprehension, information retrieval and synthesising skills of the students to solve.

Designing a good open-book examination

- Set questions that require students to do things with the information available to them, rather than to merely locate the correct information and then summarize or rewrite it.
- The questions in open-book exam must take advantage of the format, and give more weightage

to the application of knowledge, critical thinking and use of resources for solving real complex engineering problems.

- As the nature of questions is complex, it is to be ensured that the students get enough time. Open book test questions typically take longer time compared to traditional examinations. It is advisable either to set less number of questions that encompass 2 or 3 concepts taught or allocate longer duration of time for the examinations.

References:

1. Lueny Morell, Engineering Education in the 21st Century: Roles, Opportunities and Challenges (2010) Int. J. Technol. Eng. Educ. Vol.7, No.2, p. 1-10
2. Miller, A.H., Imrie, B.W. & Cox, K. (1998). Student Assessment in Higher Education. London, UK: Kogan
3. Felder, R.M. & Brent, R. (2003). Designing and teaching courses to address the ABET engineering criteria. J. Engr. Education 92(1), p. 7–25
4. Shuman, L. J., Besterfield-Sacre, M., and McGourty, J. (2005). The ABET “Professional Skills”- Can They Be Taught? Can They Be Assessed? Journal of Engineering Education, p. 41-55.
5. University of Toronto. Report on the Outcomes and Indicators for the CEAB Graduate Attributes Process, Faculty of Applied Science and Engineering University of Toronto http://www.engineering.utoronto.ca/wp-content/blogs.dir/28/files/2015/02/Revised-UCC-Grad-Att-Cover2c-Rpt-26-Table_Apr-11-2012.pdf. (available as on April 12, 2018)
6. Bloom, B.S., Engelhart, M.D., Furst, E.J., Hill, W.H. and Krathwohl, D.R. 1956 Taxonomy of educational objectives Handbook 1: cognitive domain. London, Longman Group Ltd.
7. Anderson, L.W., Krathwohl, D.R., Airasian, P.W., Cruikshank, K.A., Mayer, R.E., Pintrich, P.R., Raths, J. and Wittrock, M.C. (eds.) (2001). A taxonomy for learning and teaching and assessing: A revision of Bloom’s taxonomy of educational objectives. Addison Wesley Longman.
8. Illinois online network, Assessing Learning Objectives Bloom’s Taxonomy, <http://www.ion.uillinois.edu/resources/tutorials/assessment/bloomtaxonomy.asp> (available as on April 12, 2018)
9. Chan, CKY (2015). “Rubrics for Engineering Education”, Engineering Education Enhancement and Research Asia (E3R Asia)
10. Rogers, G. (2010). Developing rubrics. Retrieved from http://www.abet.org/uploadedFiles/Events/Webinars/Developing_Rubrics.pdf

APPENDIX

Competencies and Performance Indicators (PIs)

Computer Science & Engineering/Information Technology Programs

Appendix-A

PO 1: Engineering knowledge: Apply the knowledge of mathematics, science, engineering fundamentals, and an engineering specialisation for the solution of complex engineering problems.

Competency	Indicators
1.2 Demonstrate competence in mathematical modelling	1.2.1 Apply the knowledge of discrete structures, linear algebra, statistics and numerical techniques to solve problems 1.2.2 Apply the concepts of probability, statistics and queuing theory in modeling of computer-based system, data and network protocols.
1.5 Demonstrate competence in basic sciences	1.5.1 Apply laws of natural science to an engineering problem
1.6 Demonstrate competence in engineering fundamentals	1.6.1 Apply engineering fundamentals
1.7 Demonstrate competence in specialized engineering knowledge to the program	1.7.1 Apply theory and principles of computer science and engineering to solve an engineering problem

PO 2: Problem analysis: Identify, formulate, research literature, and analyse complex engineering problems reaching substantiated conclusions using first principles of mathematics, natural sciences, and engineering sciences.

Competency	Indicators
2.1 Demonstrate an ability to identify and formulate complex engineering problem	2.5.1 Evaluate problem statements and identifies objectives 2.5.2 Identify processes/modules/algorithms of a computer-based system and parameters to solve a problem 2.5.3 Identify mathematical algorithmic knowledge that applies to a given problem
2.6 Demonstrate an ability to formulate a solution plan and methodology for an engineering problem	2.6.1 Reframe the computer-based system into interconnected subsystems 2.6.2 Identify functionalities and computing resources. 2.6.3 Identify existing solution/methods to solve the problem, including forming justified approximations and assumptions 2.6.4 Compare and contrast alternative solution/methods to select the best methods 2.6.5 Compare and contrast alternative solution processes to select the best process.
2.7 Demonstrate an ability to formulate and interpret a model	2.7.1 Able to apply computer engineering principles to formulate modules of a system with required applicability and performance. 2.7.2 Identify design constraints for required performance criteria.
2.8 Demonstrate an ability to execute a solution process and analyze results	2.8.1 Applies engineering mathematics to implement the solution. 2.8.2 Analyze and interpret the results using contemporary tools. 2.8.3 Identify the limitations of the solution and sources/causes. 2.8.4 Arrive at conclusions with respect to the objectives.

PO 3: Design/Development of Solutions: Design solutions for complex engineering problems and design system components or processes that meet the specified needs with appropriate consideration for public health and safety, and cultural, societal, and environmental considerations.

Competency	Indicators
3.5 Demonstrate an ability to define a complex/open-ended problem in engineering terms	3.5.1 Able to define a precise problem statement with objectives and scope. 3.5.2 Able to identify and document system requirements from stake- holders. 3.5.3 Able to review state-of-the-art literature to synthesize system requirements. 3.5.4 Able to choose appropriate quality attributes as defined by ISO/IEC/IEEE standard. 3.5.5 Explore and synthesize system requirements from larger social and professional concerns. 3.5.6 Able to develop software requirement specifications (SRS).
3.6 Demonstrate an ability to generate a diverse set of alternative design solutions	3.6.1 Able to explore design alternatives. 3.6.2 Able to produce a variety of potential design solutions suited to meet functional requirements. 3.6.3 Identify suitable non-functional requirements for evaluation of alternate design solutions.
3.7 Demonstrate an ability to select optimal design scheme for further development	3.7.1 Able to perform systematic evaluation of the degree to which several design concepts meet the criteria. 3.7.2 Consult with domain experts and stakeholders to select candidate engineering design solution for further development
3.8 Demonstrate an ability to advance an engineering design to defined end state	3.8.1 Able to refine architecture design into a detailed design within the existing constraints. 3.8.2 Able to implement and integrate the modules. 3.8.3 Able to verify the functionalities and validate the design.

PO 4: Conduct investigations of complex problems: Use research-based knowledge and research methods including design of experiments, analysis and interpretation of data, and synthesis of the information to provide valid conclusions.

Competency	Indicators
4.4 Demonstrate an ability to conduct investigations of technical issues consistent with their level of knowledge and understanding	4.4.1 Define a problem for purposes of investigation, its scope and importance 4.4.2 Able to choose appropriate procedure/algorithm, dataset and test cases. 4.4.3 Able to choose appropriate hardware/software tools to conduct the experiment.
4.5 Demonstrate an ability to design experiments to solve open-ended problems	4.5.1 Design and develop appropriate procedures/methodologies based on the study objectives
4.6 Demonstrate an ability to analyze data and reach a valid conclusion	4.6.1 Use appropriate procedures, tools and techniques to collect and analyze data 4.6.2 Critically analyze data for trends and correlations, stating possible errors and limitations 4.6.3 Represent data (in tabular and/or graphical forms) so as to facilitate analysis and explanation of the data, and drawing of conclusions 4.6.4 Synthesize information and knowledge about the problem from the raw data to reach appropriate conclusions

PO 5: Modern tool usage: Create, select, and apply appropriate techniques, resources, and modern engineering and IT tools including prediction and modelling to complex engineering activities with an understanding of the limitations.

Competency		Indicators	
5.4	Demonstrate an ability to identify/create modern engineering tools, techniques and resources	5.4.1	Identify modern engineering tools, techniques and resources for engineering activities
		5.4.2	Create/adapt/modify/extend tools and techniques to solve engineering problems
5.5	Demonstrate an ability to select and apply discipline-specific tools, techniques and resources	5.5.1	Identify the strengths and limitations of tools for (i) acquiring information, (ii) modeling and simulating, (iii) monitoring system performance, and (iv) creating engineering designs.
		5.5.2	Demonstrate proficiency in using discipline-specific tools
5.6	Demonstrate an ability to evaluate the suitability and limitations of tools used to solve an engineering problem	5.6.1	Discuss limitations and validate tools, techniques and resources
		5.6.2	Verify the credibility of results from tool use with reference to the accuracy and limitations, and the assumptions inherent in their use.

PO 6: The engineer and society: Apply reasoning informed by the contextual knowledge to assess societal, health, safety, legal, and cultural issues and the consequent responsibilities relevant to the professional engineering practice.

Competency		Indicators	
6.3	Demonstrate an ability to describe engineering roles in a broader context, e.g. pertaining to the environment, health, safety, legal and public welfare	6.3.1	Identify and describe various engineering roles; particularly as pertains to protection of the public and public interest at the global, regional and local level
6.4	Demonstrate an understanding of professional engineering regulations, legislation and standards	6.4.1	Interpret legislation, regulations, codes, and standards relevant to your discipline and explain its contribution to the protection of the public

PO 7: Environment and sustainability: Understand the impact of the professional engineering solutions in societal and environmental contexts, and demonstrate the knowledge of, and the need for sustainable development.

Competency		Indicators	
7.3	Demonstrate an understanding of the impact of engineering and industrial practices on social, environmental and in economic contexts	7.3.1	Identify risks/impacts in the life-cycle of an engineering product or activity
		7.3.2	Understand the relationship between the technical, socio-economic and environmental dimensions of sustainability
7.4	Demonstrate an ability to apply principles of sustainable design and development	7.4.1	Describe management techniques for sustainable development
		7.4.2	Apply principles of preventive engineering and sustainable development to an engineering activity or product relevant to the discipline

PO 8: Ethics: Apply ethical principles and commit to professional ethics and responsibilities and norms of the engineering practice.

Competency		Indicators	
8.3	Demonstrate an ability to recognize ethical dilemmas	8.3.1	Identify situations of unethical professional conduct and propose ethical alternatives

8.4	Demonstrate an ability to apply the Code of Ethics	8.4.1 Identify tenets of the ASME professional code of ethics 8.4.2 Examine and apply moral & ethical principles to known case studies
PO 9: Individual and team work: Function effectively as an individual, and as a member or leader in diverse teams, and in multidisciplinary settings.		
Competency		Indicators
9.4	Demonstrate an ability to form a team and define a role for each member	9.4.1 Recognize a variety of working and learning preferences; appreciate the value of diversity on a team 9.4.2 Implement the norms of practice (e.g. rules, roles, charters, agendas, etc.) of effective team work, to accomplish a goal.
9.5	Demonstrate effective individual and team operations--communication, problem-solving, conflict resolution and leadership skills	9.5.1 Demonstrate effective communication, problem-solving, conflict resolution and leadership skills 9.5.2 Treat other team members respectfully 9.5.3 Listen to other members 9.5.4 Maintain composure in difficult situations
9.6	Demonstrate success in a team-based project	9.6.1 Present results as a team, with smooth integration of contributions from all individual efforts
PO 10: Communication: Communicate effectively on complex engineering activities with the engineering community and with the society at large, such as being able to comprehend and write effective reports and design documentation, make effective presentations, and give and receive clear instructions		
Competency		Indicators
10.4	Demonstrate an ability to comprehend technical literature and document project work	10.4.1 Read, understand and interpret technical and non-technical information 10.4.2 Produce clear, well-constructed, and well-supported written engineering documents 10.4.3 Create flow in a document or presentation - a logical progression of ideas so that the main point is clear
10.5	Demonstrate competence in listening, speaking, and presentation	10.5.1 Listen to and comprehend information, instructions, and viewpoints of others 10.5.2 Deliver effective oral presentations to technical and non-technical audiences
10.6	Demonstrate the ability to integrate different modes of communication	10.6.1 Create engineering-standard figures, reports and drawings to complement writing and presentations 10.6.2 Use a variety of media effectively to convey a message in a document or a presentation
PO 11: Project management and finance: Demonstrate knowledge and understanding of the engineering and management principles and apply these to one's work, as a member and leader in a team, to manage projects and in multidisciplinary environments.		
Competency		Indicators
11.4	Demonstrate an ability to evaluate the economic and financial performance of an engineering activity	11.4.1 Describe various economic and financial costs/benefits of an engineering activity 11.4.2 Analyze different forms of financial statements to evaluate the financial status of an engineering project
11.5	Demonstrate an ability to compare and contrast the costs/benefits of alternate proposals for an engineering activity	11.5.1 Analyze and select the most appropriate proposal based on economic and financial considerations.

11.6	Demonstrate an ability to plan/manage an engineering activity within time and budget constraints	11.6.1 Identify the tasks required to complete an engineering activity, and the resources required to complete the tasks. 11.6.2 Use project management tools to schedule an engineering project, so it is completed on time and on budget.
PO 12: Life-long learning: Recognise the need for, and have the preparation and ability to engage in independent and life-long learning in the broadest context of technological change.		
Competency		Indicators
12.4	Demonstrate an ability to identify gaps in knowledge and a strategy to close these gaps	12.4.1 Describe the rationale for the requirement for continuing professional development 12.4.2 Identify deficiencies or gaps in knowledge and demonstrate an ability to source information to close this gap
12.5	Demonstrate an ability to identify changing trends in engineering knowledge and practice	12.5.1 Identify historic points of technological advance in engineering that required practitioners to seek education in order to stay current 12.5.2 Recognize the need and be able to clearly explain why it is vitally important to keep current regarding new developments in your field
12.6	Demonstrate an ability to identify and access sources for new information	12.6.1 Source and comprehend technical literature and other credible sources of information 12.6.2 Analyze sourced technical and popular information for feasibility, viability, sustainability, etc.

APPENDIX

Sample questions for Bloom's Taxonomy levels

Appendix-B

SAMPLES QUESTIONS FOR BLOOMS TAXONOMY LEVELS:

1. REMEMBER

Skill Demonstrated	Question Ques / Verbs for tests
<ul style="list-style-type: none">Ability to recall of information like, facts, conventions, definitions, jargon, technical terms, classifications, categories, and criteriaability to recall methodology and procedures, abstractions, principles, and theories in the fieldknowledge of dates, events, placesmastery of subject matter	list, define, describe, state, recite, recall, identify, show, label, tabulate, quote, name, who, when, where, etc.

Sample Questions:

1. State Ohm's law
2. List the physical and chemical properties of silicon
3. List the components of A/D converter
4. List the arithmetic operators available in C in increasing order of precedence.
5. Define the purpose of a constructor.
6. Define the terms: Sensible heat, Latent heat and Total heat of evaporation
7. List the assembler directives.
8. Describe the process of galvanisation and tinning
9. Write truth table and symbol of AND, OR, NOT, XNOR gates
10. Define the terms: Stress, Working stress and Factor of safety.
11. What is the difference between declaration and definition of a variable/function?
12. List the different storage class specifiers in C.
13. What is the use of local variables?
14. What is a pointer to a pointer?
15. What are the valid places for the keyword "break" to appear?
16. What is a self-referential structure?

2. UNDERSTAND

Skill Demonstrated	Question Ques / Verbs for tests
<ul style="list-style-type: none">• understanding information• grasp meaning• translate knowledge into new context• interpret facts, compare, contrast• order, group, infer causes• predict consequences	describe, explain, paraphrase, restate, associate, contrast, summarize, differentiate interpret, discuss

Sample Questions:

1. Explain the importance of sustainability in Engineering design
2. Explain the behaviour of PN junction diode under different bias conditions
3. Describe the characteristics of SCR and transistor equivalent for a SCR
4. Explain the terms: Particle, Rigid body and Deformable body giving two examples for each.
5. How many values of the variable num must be used to completely test all branches of the following code fragment?

```
if (num > 0)
    if (value < 25)
    {
        value = 10 * num;
        if (num < 12)
            value = value / 10;
    }
else
    Value = 20 * num;
else
    Value = 30 * num
```

6. Discuss the effect of Make in India initiative on the Indian manufacturing Industry.
7. Summarise the importance of ethical code of conduct for engineering professionals
8. Explain the syntax for 'for loop'.
9. What is the difference between including the header file with-in angular braces < > and double quotes " "?
10. What is the meaning of base address of the array?
11. What is the difference between actual and formal parameters?
12. Explain the different ways of passing parameters to the functions.
13. Explain the use of comma operator (,).
14. Differentiate between entry and exit controlled loops.
15. How is an array different from linked list?

3. APPLY

Skill Demonstrated	Question Ques / Verbs for tests
<ul style="list-style-type: none"> use information use methods, concepts, laws, theories in new situations solve problems using required skills or knowledge Demonstrating correct usage of a method or procedure 	calculate, predict, apply, solve, illustrate, use, demonstrate, determine, model, experiment, show, examine, modify

Sample Questions:

- Model and realize the following behaviors using diodes with minimum number of digital inputs.
 - Turning on of a burglar alarm only during night time when the locker door is opened.
 - Providing access to an account if either date of birth or registered mobile number or both are correct.
 - Updating the parking slot empty light in the basement of a shopping mall.
- One of the resource persons needs to address a huge crowd (nearly 400 members) in the auditorium. A system is to be designed in such a way that everybody attending the session should be able to hear properly and clearly without any disturbance. Identify the suitable circuit to boost the voice signal and explain its functionality in brief.
- A ladder 5.0 m long rests on a horizontal ground & leans against a smooth vertical wall at an angle 20° with the vertical. The weight of the ladder is 900 N and acts at its middle. The ladder is at the point of sliding, when a man weighing 750 N stands on a rung 1.5 m from the bottom of the ladder. Calculate the coefficient of friction between the ladder & the floor.
- A ball is dropped from 6 meters above a flat surface. Each time the ball hits the surface after falling a distance h , it rebounds a distance rh . What will be the total distance the ball travels in each of the following cases.
 - $r > 1$
 - $0 < r < 1$
 - $r = 1$

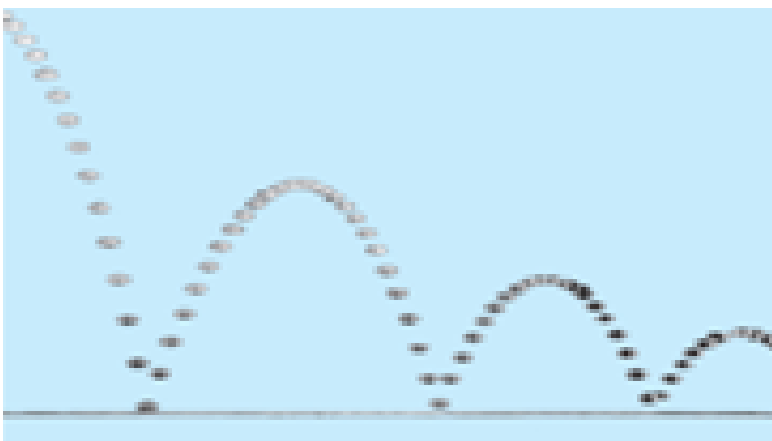

- The region bounded by the curves $y = e^{(-1)x}$, $y = 0$, $x = 1$, and $x = 5$ is rotated about the x -axis. Use Simpson's Rule with $n = 8$ to estimate the volume of the resulting solid.
- An electric train is powered by machine which takes the supply from 220 V DC rail running above the train throughout. Machine draws current of 100 A from the DC rail to account for high torque during starting and runs at 700 r.p.m initially. Calculate the new speed of the train once it picks up the speed

where the torque output required is only 70% of starting torque. Assume the motor has a resistance of 0.1Ω across its terminals.

7. Write an algorithm to implement a stack using queue.
8. A single array $A[1..MAXSIZE]$ is used to implement two stacks. The two stacks grow from opposite ends of the array. Variables $top1$ and $top2$ ($top1 < top2$) point to the location of the topmost element in each of the stacks. What is the condition for “stack full”, if the space is to be used efficiently.
9. Consider the following table of arrival time and burst time for three processes P0, P1 and P2.

Process	Arrival time	Burst Time
P0	0 ms	9 ms
P1	1 ms	4 ms
P2	2 ms	9 ms

The pre-emptive shortest job first scheduling algorithm is used. Scheduling is carried out only at arrival or completion of processes. What is the average waiting time for the three processes?

10. A CPU generates 32-bit virtual addresses. The page size is 4 KB. The processor has a translation look-aside buffer (TLB) which can hold a total of 128-page table entries and is 4-way set associative. What is the minimum size of the TLB tag?

4. ANALYZE

Skill Demonstrated	Question Ques / Verbs for tests
<ul style="list-style-type: none"> • break down a complex problem into parts. • Identify the relationships and interaction between the different parts of complex problem 	classify, outline, break down, categorize, analyse, diagram, illustrate, infer, select

Sample Questions:

1. A class of 10 students consists of 5 males and 5 females. We intend to train a model based on their past scores to predict the future score. The average score of females is 60 whereas that of male is 80. The overall average of the class is 70. Give two ways of predicting the score and analyse them for fitting model.
2. Suppose that we want to select between two prediction models, M1 and M2. We have performed 10 rounds of 10-fold cross-validation on each model, whereas the same data partitioning in round one is used for both M1 and M2. The error rates obtained for M1 are 30.5, 32.2, 20.7, 20.6, 31.0, 41.0, 27.7, 26.0, 21.5, 26.0. The error rates for M2 are 22.4, 14.5, 22.4, 19.6, 20.7, 20.4, 22.1, 19.4, 16.2, 35.0. Comment on whether one model is significantly better than the other considering a significance level of 1%.
3. Return statement can only be used to return a single value. Can multiple values be returned from a function? Justify your answer.
4. Bob wrote a program using functions to find sum of two numbers whereas Alex wrote the statements to find the sum of two numbers in the main() function only. Which of the two methods is efficient in execution and why?
5. Carly wants to store the details of students studying in 1st year and later on wishes to retrieve the

information about the students who score the highest marks in each subject. Specify the scenario where the data can be organized as a single 2-D array or as multiple 1-D arrays.

6. Dave is working on a Campus Management Software but is unable to identify the maximum number of students per course. He decided to implement the same using arrays but discovered that there is memory wastage due to over-provisioning. Which method of memory storage should be used by Dave and how it can be implemented using C?
7. Albert is working on a 32-bit machine whereas Julie is working on a 64-bit machine. Both wrote the same code to find factorial of a number but Albert is unable to find factorial of a number till 9 whereas Julie is able to find the factorial of higher number. Identify the possible reason why Albert is unable to find the factorial. Suggest some changes in the code so that Albert can handle bigger inputs.
8. While writing a C code, the problem faced by the programmers is to find if the parenthesis is balanced or not. Write an algorithm to check if the parenthesis in C code are balanced. Initially your code should work for balanced { and } braces.
9. Swapping of the data in a linked list can be performed by swapping the contents in the linked list. Can the contents of a linked list be swapped without actually swapping the data?

5. EVALUATE

Skill Demonstrated	Question Ques / Verbs for tests
<ul style="list-style-type: none"> • compare and discriminate between ideas • assess value of theories, presentations • make choices based on reasoned argument • verify value of evidence • recognize subjectivity • use of definite criteria for judgments 	assess, decide, choose, rank, grade, test, measure, defend, recommend, convince, select, judge, support, conclude, argue, justify, compare, summarize, evaluate

6. CREATE

Skill Demonstrated	Question Ques / Verbs for tests
<ul style="list-style-type: none"> • use old ideas to create new ones • Combine parts to make (new) whole, • generalize from given facts • relate knowledge from several areas • predict, draw conclusions 	design, formulate, build, invent, create, compose, generate, derive, modify, develop, integrate

Both higher order cognitive skills 'Evaluate' and 'Create' are difficult to assess in time-limited examinations. These need to be assessed in variety of student works like projects, open ended problem-solving exercises etc. Typical examples of problem statements or need statements which need higher order abilities to solve are given below

Sample Problem / Need statements:

1. Automatic tethering of milking machine to the udder of a cow. A milk diary wants to automate the milking process. The milking process involves attaching the milking cups to the teats. Design a system for the same.
2. An electric vehicle uses LiON batteries. The batteries have to be charged and get discharged during use.

The batteries require continuous monitoring during charging and discharging so that they remain healthy and yield a long life. Design a system to monitor and manage the health of the batteries.

3. A Biotech industry needs automation for filling its product into 20 ltr bottles. Design a system to meter the flow into the bottles so that each bottle has 20 ltr of the liquid. There will be more than one filling station and the system has to monitor all the filling stations as well as keep count of the total production on a daily basis.
4. Microwave Doppler radar with a range of 9m are available for motion detection. Design a surround view monitoring system for a 3 wheeler to detect human obstacles while the vehicle is in motion.
5. Design a system to assist the driver by using cameras to detect lane markers and pedestrians while the vehicle is in motion.
6. Develop a small size USB 2.0 / 3.0 CMOS camera system which can be used for industrial inspection, medical applications, microscopy, etc. The system should be able to capture the image quickly and be able to process the captured image and then store it also

APPENDIX

Model Question Papers

Appendix-C

MODEL QUESTION PAPER

Course: Programming for Problem solving (ESC 103)

Maximum Marks :100; Duration: 03 hours

Q.No	Questions	Marks	CO	BL	PI
1(a)	Explain the steps involved in solving a problem using computer.	08	CO1	L2	1.4.1
1(b)	Write an algorithm to find roots of a quadratic equation $ax^2 + bx + c = 0$ reading the values of a, b and c.	12	CO2	L3	1.4.1
2(a)	Compare if-else-if and switch statement giving examples for their relevant use.	08	CO2	L2	1.4.1
2b	Write a C program that reads a given integer number and checks whether it a palindrome. A palindrome is a number that has same value even when it is reversed. Eg: 12321 is a palindrome.	12	CO3	L3	1.4.1
3a	Compare the working of three looping constructs of C language giving their syntax.	08	CO3	L2	1.4.1
3b	What does the following program do? <pre>#include <stdio.h> int main() { char ch; int vcnt = 0, ccnt=0; for (ch = getchar(); ch != '\n'; ch=getchar()){ if(ch=='a' ch=='e' ch=='i' ch=='o' ch=='u' ch=='A' ch=='E' ch=='I' ch=='O' ch=='U') vcnt++; else if((ch >= 'a' && ch <= 'z') (ch >= 'A' && ch <= 'Z')) ccnt++; } printf(" %d %d\n", vcnt, ccnt); }</pre> Rewrite the above program using while and switch constructs.	12	CO4	L4	1.4.1
4a	Compare call by value and call by reference with relevant examples.	8	CO3	L2	1.4.1
4b	Write a C function to find the largest and smallest in a given list of integers of size n using call by reference: void minmax(int list[], int n, int *min, int *max);	12	CO3	L3	1.4.1
5a	Explain at least four file handling operations available in C language giving their syntax.	4	CO3	L2	1.4.1
5b	Identify the bug in the following function written to return the swapped values of two integer variables given:				

	<pre>int swap(int *x, int *y) { int *temp; temp = x, x=y, y = temp; }</pre>	6	C05	L4	1.4.1
5c	Define a structure to store time with three components hours, mins and seconds. Write a modular C program to compute the time taken by an athlete to complete a marathon reading the start and end time of his run.	10	C03	L3	1.4.1

BL – Bloom’s Taxonomy Levels (1- Remembering, 2- Understanding, 3 – Applying, 4 – Analysing, 5 – Evaluating, 6 - Creating)

CO – Course Outcomes

PO – Program Outcomes; PI Code – Performance Indicator Code

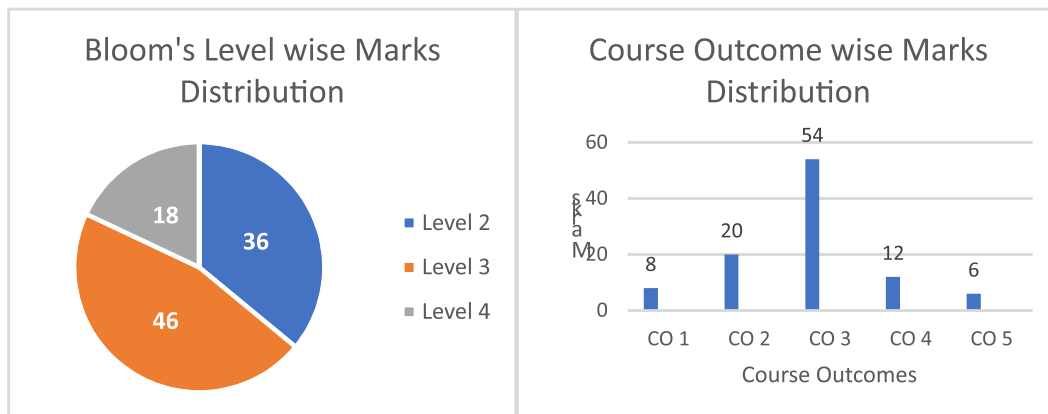

MODEL QUESTION PAPER FOR END SEMESTER EXAMINATION

Course Name: Programming for Problem Solving

Duration: 3 hrs. ; Max. Marks: 100

Instructions:

- Attempt five questions selecting ONE from each section. Question 9 (Section E) is compulsory.
- All the questions carry equal marks.
- Draw neat diagrams wherever applicable.

Q. No	Question	Marks	BL	CO	PO	PI Code
Section-A						
1.	a. What is an algorithm? Explain the characteristics of an algorithm.	2+6	1,2	2	1	1.4.1
	b. Write an algorithm to find angle between hour and minute hands of a clock at a given time.	7	3	3	1	1.4.1
	c. Is it mandatory to declare main() function with return type as void or int. What will be the effect if there is no return type declared for main() function?	3+2	4	3	1	1.4.1
OR						
2.	a. What is the difference between definition and declaration in C? When a user writes "int x;" is it treated as declaration or definition in C.	3+2	2,4	3	1	1.4.1
	b. Write a program in C to find largest of 3 positive integer numbers using conditional operators.	7	3	3	1,2	1.4.1, 2.2.4
	c. What is meant by iterative statements? What are the different types of iterative statements in C?	8	1,2	3	1	1.4.1
Section-B						
3.	a. Bob has placed N objects in a row which are marked with a number equal to their weight in Kg. He wants to check whether the objects are in increasing order of their weights or not. Write a C program to help Bob.	12	3	3,6,7	1,2	1.4.1, 2.2.4
	b. Differentiate between Big-O and Big-Omega notation.	4	2	3	1	1.4.1
	c. What is the role of index in an array? How are the elements of a 2D array accessed in C?	2+2	2	3	1	1.4.1
OR						
4.	a. Ram is conducting a study which is based on counting the number of cars crossing the highway. Every hour he generates a random string containing sequence of characters <rbwbwr...>, where r represents red color, w denotes white color and b denotes blue color cars. The string is forwarded to Shyam for analysis who computes the number of red, blue and white color cars crossing Ram every hour. Assume that Ram works for 5 hours in a day, help Shyam generate a daily report containing the following: <ol style="list-style-type: none"> Total number of different colour cars crossing Ram in an hour. Total number of different colour cars crossing Ram in a day. Total number of cars crossing Ram in a day. 	4+4+4	3	3,6,7	1,2	1.4.1, 2.2.4

	b. What is a variable? Explain the ways to declare scope of a variable.	2+6	1,2	3	1	1.4.1
Section-C						
5.	a. Write a program which will read positive integer numbers from the users and compute the sum if the number can be expressed as power of 2. The test whether a number can be expressed as power of 2 will be done using a function power_of_two(int a).	12	3	3,6,7	1,2	1.4.1
	b. What is recursion? Differentiate between homogeneous and heterogeneous recursion with the help of an example.	2+3+3	2	3	1	1.4.1
OR						
6.	a. What are the different ways to pass parameters to a function? Explain with the help of a suitable example.	4+4	2	3,5	1	1.4.1
	b. Is it possible to return multiple values from a function? Justify the statement with the help of an example.	4+8	3	3,6,7	1,2	1.4.1
Section-D						
7.	a. What is a structure? What is the benefit offered by using a structure over multiple arrays?	2+6	2	5	1	1.4.1
	b. Ram is working on a project which requires returning multiple values from a function. He observed that a return statement can only be used to return a single value from a function. How the function should be implemented so that multiple values can be returned by Ram?	12	4	5	1	1.4.1
OR						
8.	a. Write a program that reads a number as input from the user. The entered number is written to a file "even.txt" if the input is even else it is written to "odd.txt". Write a C code to perform the desired task.	12	3	5	1	1.4.1
	b. What are the different methods to open a file? Explain each with the help of a C program.	3+5	2	5	1	1.4.1
Section-E (Compulsory Question)						
9.	a. What is a compiler? List names of any 2 compilers.	2 ½	1	1	1	1.4.1
	b. What are the benefits of designing a flowchart for solving a problem?	2 ½	4	2	1	1.4.1
	c. What is the output of the following code? int main(){ int x=10; int y=sizeof(x/2); printf("%d",y); }	2 ½	3	4	1	1.4.1
	d. What is the difference between creating constant using #define macro and const keyword?	2 ½	3	3	1	1.4.1
	e. What is the role of function prototype? When is it required in C?	2 ½	2	3	1	1.4.1
	f. Which of the following are unary operators in C? State reason for your answer. a. ! b. sizeof c. ~ d. &&	2 ½	2	3	1	1.4.1

g. Which of the following special symbol allowed in a variable name? State reason for your answer. a. * (asterisk) b. (pipeline) c. - (hyphen) d. _ (underscore)	2 ½	2	3	1	1.4.1
h. In which header file is the NULL macro defined? State reason for your answer. a. stdio.h b. stddef.h c. stdio.h and stddef.h d. math.h	2 ½	2	3	1	1.4.1

BL – Bloom’s Taxonomy Levels (1- Remembering, 2- Understanding, 3 – Applying, 4 – Analysing, 5 – Evaluating, 6 - Creating)

CO – Course Outcomes

PO – Program Outcomes; PI Code – Performance Indicator Code

MODEL QUESTION PAPER

Total Duration (H:M): 3:00

Course : Basic Electrical Engineering (ESC101)

Maximum Marks :100

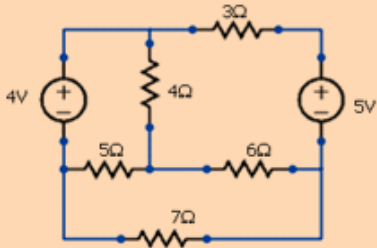
Q.No	Questions	Marks	CO	BL	PI
1(a)	Calculate current through 4 Ω resistor using Kirchoff’s Laws? Verify the same using Superposition Theorem. 	12	CO1	L3	1.3.1
1(b)	Derive the expression for the transient current in a series ‘R-L’ circuit when a ‘dc’ voltage of V volts is applied. Sketch time variation of current in the circuit.	8	CO1	L2	1.3.1
2(a)	Two impedances $Z_1 = 15 + j12\Omega$ and $Z_2 = 8 - j5\Omega$ are connected in parallel. If the potential difference across one of the impedance is 250 V, calculate i) total current and branch currents ii) total power and power consumed in each branch iii) overall p.f. IV) draw the phasor diagram	12	CO2	L3	1.3.1
2b	It is desired to operate a 100 W, 120 V, electric bulb at its rated current on a 240 V, 50 Hz supply. The simplest arrangement is to use either (a) a resistor, or (b) a capacitor or (c) an inductor having 10 Ω resistance in series with the electric bulb so as to drop the excess voltage. Determine the value of the component used, the total power consumed and the power factor in each case. Giving reasons, state which alternative is the best.	8	CO2	L4	1.3.1

3a	A single phase 25 kVA 1000/2000 V, 50 Hz transformer has maximum efficiency of 98% at full load upf. Determine its efficiency at, (a) 3/4th full load, unity power factor (b) 3/4th full load 0.8 power factor	12	C03	L3	1.3.1
3b	Explain the working of a practical transformer with relevant phasor diagram. and define voltage regulation.	8	C03	L2	1.3.1
4a	A two pole 3 phase 50 Hz induction motor is running on load with a slip of 4%. Calculate the actual speed and the synchronous speed of the machine. Sketch the speed/ load characteristic of the machine.	8	C04	L2	1.3.1
4b	A wireless battery powered drilling machine operates on 24 V DC with constant speed and negligible field current. Initially when the machine is powered it runs at 1200 rpm and draws 0.5 A from the battery. Further when the drill bit starts drilling the hole, the speed reduces to 1120 rpm. Determine power requirement from the battery for drilling if the resistance of the armature is 0.2Ω. What is the power drawn initially?	12	C04	L4	1.3.1
5a	Explain the working principle of a single phase pulse width modulated voltage source inverter with relevant circuit diagram and draw the output voltage wave form.	8	C05	L2	1.3.1
5b	To protect an expensive circuit component from being delivered too much power, you decide to incorporate a fast blowing fuse into the design. Knowing that the circuit component is connected to 12 V, its minimum power consumption is 12 watts and the maximum power it can safely dissipate is 100 watts, which of the three available fuse ratings should you select: 1A , 4A or 10 A? Give reasons.	6	C06	L4	1.3.1
5c	Calculate the i) ampere-hour and ii) watt-hour efficiency of a secondary cell which is discharged at a uniform rate of 30 A for 6 hours at an average terminal voltage of 2 V. It is then charged at a uniform rate of 40 A for 5 hours to restore it to its original condition. The terminal voltage during charging is 2.5 V.	6	C06	L3	1.3.1

BL – Bloom’s Taxonomy Levels (1- Remembering, 2- Understanding, 3 – Applying, 4 – Analysing, 5 – Evaluating, 6 - Creating)

CO – Course Outcomes

PO – Program Outcomes; PI Code – Performance Indicator Code

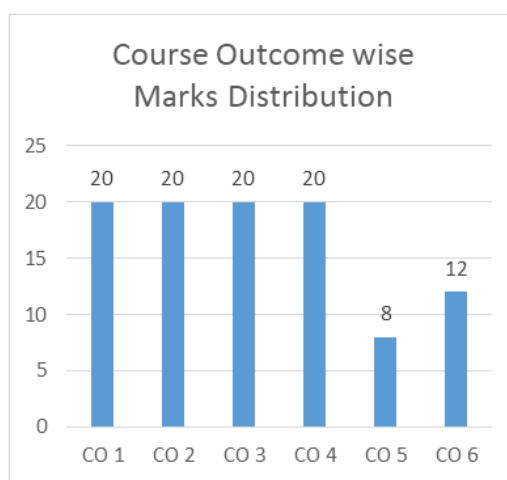
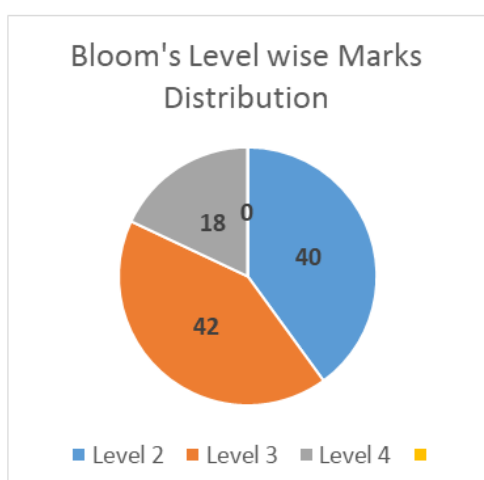

APPENDIX

Sample Scoring Rubrics

Appendix-D

RUBRICS FOR COMMUNICATION (WRITTEN & ORAL)

Component	Proficient	Acceptable	Needs Improvements
Written Communication	Report is well organized and clearly written. The underlying logic is clearly articulated and easy to follow. Words are chosen that precisely express the intended meaning and support reader comprehension. Diagrams or analyses enhance and clarify presentation of ideas. Sentences are grammatical and free from spelling errors.	Report is organized and clearly written for the most part. In some areas the logic or flow of ideas is difficult to follow. Words are well chosen with some minor exceptions. Diagrams are consistent with the text. Sentences are mostly grammatical and only a few spelling errors are present but they do not hinder the reader.	Report lacks an overall organization. Reader has to make considerable effort to understand the underlying logic and flow of ideas. Diagrams are absent or inconsistent with the text. Grammatical and spelling errors make it difficult for the reader to interpret the text in places.
Presentation Visual Aids	Slides are error-free and logically present the main components of the process and recommendations. Material is readable and the graphics highlight and support the main ideas.	Slides are error-free and logically present the main components of the process and recommendations. Material is mostly readable and graphics reiterate the main ideas.	Slides contain errors and lack a logical progression. Major aspects of the analysis or recommendations are absent. Diagrams or graphics are absent or confuse the audience.
Oral Presentation	Speakers are audible and fluent on their topic, and do not rely on notes to present or respond. Speakers respond accurately and appropriately to audience questions and comments.	Speakers are mostly audible and fluent on their topic, and require minimal referral to notes. Speakers respond to most questions accurately and appropriately.	Speakers are often inaudible or hesitant, often speaking in incomplete sentences. Speakers rely heavily on notes. Speakers have difficulty responding clearly and accurately to audience questions.
Body Language	Body language, as indicated by appropriate and meaningful gestures (e.g., drawing hands inward to convey contraction, moving arms up to convey lift, etc.) eye contact with audience, and movement, demonstrates a high level of comfort and connection with the audience.	Body language, as indicated by a slight tendency to repetitive and distracting gestures (e.g., tapping a pen, wringing hands, waving arms, clenching fists, etc.) and breaking eye contact with audience, demonstrates a slight discomfort with the audience.	Body language, as indicated by frequent, repetitive and distracting gestures, little or no audience eye-contact, and /or stiff posture and movement, indicate a high degree of discomfort interacting with audience.

RUBRICS FOR ASSESSMENT OF DESIGN PROJECTS

Category	Needs Improvements	Acceptable	Proficient
Purpose of the Project	Does not clearly explain the intended outcome of the project or provides little information about the problem that was being solved, the need being met, or why the project was selected	Provides a description of the intended outcome of the project which includes information about the problem that was being solved or the need being met, and why the project was selected	Provides a detailed intended outcome of the project which includes information about the problem that was being solved or the need being met, and clearly articulates the reasons and decision-making process used to select the project
Research	Lacks awareness of similar work done by others in an unacceptable literary form	Reflects awareness of similar work done by others and presents it in an acceptable literary format	• Reflects thorough understanding of similar work done by others and presents it in an acceptable literary format
Choices	Lacks justification of choices with little or no references to functional, aesthetic, social, economic, or environmental considerations	Justifies choices made with reference to functional, aesthetic, social, economic, or environmental considerations	Demonstrates sophisticated justification of choices with reference to functional, aesthetic, social, economic, or environmental consideration
Alternative Designs	Only one design presented or clearly infeasible alternative given. Serious deficiencies in exploring and identifying alternative designs.	Alternative approaches identified to some degree.	Final design achieved after review of reasonable alternatives.
Application of Engineering Principles	No or erroneous application of engineering principles yielding unreasonable solution. Serious deficiencies in proper selection and use of engineering principles.	Effective application of engineering principles resulting in reasonable solution.	Critical selection and application of engineering principles ensuring reasonable results.
Final Design	Not capable of achieving desired objectives.	Design meets desired objectives.	Design meets or exceeds desired objectives.
Interpretation of Results	No or erroneous conclusions based on achieved results. Serious deficiencies in support for stated conclusions.	Sound conclusions reached based on achieved results.	Insightful, supported conclusions and recommendations.

Rubrics can also be used effectively to design the continuous assessment of the student projects. The Performance Indicators referred to in the previous sections can be used measurement criteria in the rubric. In the following example, we can see that for different phases of the students projects, we can design the rubrics keeping in mind the deliverables of the project at that particular stage.

5 - SEMESTER MINI PROJECT

RUBRICS FOR REVIEW – I

PI Code	PI	Marks	Very Poor Up to 20%	Poor Up to 40%	Average Up to 60%	Good Up to 80%	Very good Up to 100%
2.1.1	Articulate problem statements and identify objectives - GA	02	Problem statement and objectives are not identified	Problem statement and objectives are not clear	Problem statement is clear and objectives are not in line with problem statement	Problem statement is clear and objectives are not completely defined.	Problem statement is clear and objectives are completely defined
2.1.2	Identify engineering systems, variables, and parameters to solve the problems - IA	02	Engineering systems are not identified. Variables, and parameters to solve the problems are not defined	Engineering systems are identified but not clear. Variables, and parameters to solve the problems are not defined	Engineering systems are clear. Variables, and parameters to solve the problems are not defined	Engineering systems are identified. Variables, and parameters to solve the problems are partially defined	Engineering systems are identified. Variables, and parameters to solve the problems are completely defined
2.2.3	Identify existing processes/ solution methods for solving the problem, including forming justified approximations and assumptions - GA	02	Not able to identify existing solution for solving the problem. The assumptions, approximations and justifications are also not identified.	Not able to identify existing solution for solving the problem. The assumptions, approximations and justifications are identified but not clear	Not able to identify existing solution for solving the problem. But assumptions and approximations are aligned to the objectives.	Able to identify existing solution for solving the problem. Assumptions, and approximations are clear	Able to identify existing solution for solving the problem. But assumptions, approximations and justifications are clear
2.2.4	Compare and contrast alternative solution processes to select the best process - GA	02	Not able to identify alternative solution processes	Not able to compare alternative solution processes	Able to compare alternative solution processes but could not contrast clearly	Able to compare alternative solution processes and contrast clearly but not able to select best process	Able to compare alternative solution processes, contrast it and also able to select best process
10.1.1	Read, understand and interpret technical and non-technical information - GA	02	Not able to identify technical and non-technical information	Able to identify non-technical information	Able to read technical and non-technical information, but could not understand and interpret	Able to read, understand technical and non-technical information, but could not interpret	Able to read, understand and interpret technical and non-technical information

RUBRICS FOR REVIEW – II

PI Code	PI	Marks	Very Poor Up to 20%	Poor Up to 40%	Average Up to 60%	Good Up to 80%	Very good Up to 100%
3.2.1	Apply formal idea generation tools to develop multiple engineering design solutions - GA	02	Not able to identify tools to develop solutions	Able to identify but not able to use it effectively	Able to use the tool but not able to generate engineering designs	Able to generate engineering designs but not able to justify	Able to generate engineering designs with justification
3.2.3	Identify suitable criteria for evaluation of alternate design solutions - GA	02	Not able to identify criteria	Able to identify criteria but not able to use them	Able to use criteria but not able to compare alternatives	Not able to justify the comparison with criteria	Able to justify the comparison with criteria
3.3.1	Apply formal decision-making tools to select optimal engineering design solutions for further development - GA	02	Not able to identify decision-making tools	Able to identify but not able to choose optimum one	Able to identify optimum one but not able to use it	Able to use optimum one but not able to justify	Able to use optimum one with justification
3.2.2	Build models/ prototypes to develop diverse set of design solutions - IA	02	Not able to identify tool to build model/ prototype	Able to choose the tool but not able to use it effectively	Able to use the tool but not able to generate alternatives	Able to generate alternatives but not able to justify the best solution	Able to generate and justify the best solution
13.1.1	Develop 2D drawings of components/ systems using modern CAD tools - IA	02	Not able to identify CAD tools	Able to identify but not able to use CAD tool	Able to use CAD tool but not able to generate drawings	Able to generate drawings but not able to follow drawing standards	Able to generate drawings with standards
13.1.2	Develop 3D models of components/systems using modern CAD tools - IA	03	Not able to identify CAD tools	Able to identify but not able to use CAD tool	Able to use CAD tool but not able to generate 3D models	Able to generate models but not able to follow standards	Able to generate models with standards
13.1.3	Apply GD&T principles as per ASME standards to manufacturing drawings, with all relevant data like material, hardness, surface finish, and tolerances - IA	02	Not able to extract GD&T principles from ASME standards	Able to extract but not able to understand them	Able to understand but not able to apply GD&T standards	Able to apply GD&T standards to drawings but not able to justify	Able to apply and justify GD&T standards to drawings

RUBRICS FOR REVIEW – III

PI Code	PI	Marks	Very Poor Up to 20%	Poor Up to 40%	Average Up to 60%	Good Up to 80%	Very good Up to 100%
3.4.2	Generate information through appropriate tests to improve or revise design - GA	02	Not able to identify suitable tests to be done	Able to identify but not able to follow testing procedure	Able to follow testing procedures but not able to collect information	Able to collect information but not able to apply it for improvement	Able to apply information for the improvement
4.3.1	Use appropriate procedures, tools and techniques to conduct experiments and collect data - GA	04	Not able to identify tools, techniques and procedures	Able to identify but not able to conduct experiments	Able to conduct experiments but not able to follow procedure	Able to follow procedure but not able to collect data	Able to collect data as per the standards
4.3.2	Analyze data for trends and correlations, stating possible errors and limitations - GA	03	Not able to understand data	Able to understand but not able to analyze data	Able to analyze data but not able to correlate them	Able to correlate but not able to identify errors and limitations	Able to identify errors and limitations
10.2.2	Deliver effective oral presentations to technical and non-technical audiences - IA	03	Could not deliver effective presentations.	Could not deliver presentation, but presentation was prepared and attempted.	Able to deliver fair presentation but not able to answer to the audiences	Deliver effective presentations but able to answer partially to the audience queries.	Deliver effective presentation and able to answer all queries of the audience.
9.3.1	Present results as a team, with smooth integration of contributions from all individual efforts – GA + IA	03	No Contribution from an individual to a team	Contributions from an individual to a team is minimal	Contributions from an individual to a team is moderate	A contribution from an individual to a team is good but not well groomed in team.	Contribution from an individual to a team is good and results in an integrated team presentation.

AICTE COMMITTEE ON EXAMINATION REFORMS

Members of the Committee

1. **Prof. Ashok S. Shettar, Chairman**
Vice Chancellor, KLE Technological University, Hubballi, Karnataka
2. **Prof. Rama Krishna Challa,**
Head, Dept. of Computer Science and Engineering, NITTTR, Chandigarh
3. **Prof. Sanjay Agrawal**
Dept. of Computer Engineering and Applications, NITTR, Bhopal (M.P)
4. **Prof. Upendra Pandel**
Dept. of Metallurgical & Material Engineering, MNIT, Jaipur



ALL INDIA COUNCIL FOR TECHNICAL EDUCATION
Nelson Mandela Marg, Vasant Kunj, New Delhi-110070